

# Removing Barriers

## Planning Meetings That Are Accessible To All Participants





## **Removing Barriers**

Planning Meetings  
That Are Accessible  
To All Participants

## **Other NCODH publications**

*Removing Barriers to  
Health Care:  
A Guide for Health Professionals*

*Removing Barriers:  
Tips and Strategies to Promote Ac-  
cessible Communication*

*Removing Barriers to  
Health Clubs and Fitness Centers:  
A Guide for Accommodating All  
Members, Including People with  
Disabilities and Older Adults*

*Recreation: A Great Way  
to Be Active*

*Health Promotion  
Resource Guide*

*Orchid*

## **Other resources from NCODH**

[www.fpg.unc.edu/~ncodh](http://www.fpg.unc.edu/~ncodh)

*Center for Universal Design*  
[www.design.ncsu.edu/cud](http://www.design.ncsu.edu/cud)

*ADA Technical Assistance Project*  
[www.adata.org](http://www.adata.org)





# Removing Barriers Planning Meetings That Are Accessible To All Participants

North Carolina  
Office on Disability  
and Health

in collaboration with  
The Center for  
Universal Design

2005



**UNC**

FPG

CHILD DEVELOPMENT  
INSTITUTE

## **Credits**

Developed by the North Carolina Office on Disability and Health.  
2005

The information provided in this material was supported by Grant/Cooperative Agreement Number U59/CCU419404-04 from the Centers for Disease Control and Prevention (CDC), National Center on Birth Defects and Developmental Disabilities. The contents are solely the responsibility of the authors and do not necessarily represent the official views of CDC.

The North Carolina Office on Disability and Health is a partnership of the North Carolina Division of Public Health of the Department of Health and Human Services and the FPG Child Development Institute at The University of North Carolina at Chapel Hill to promote the health and wellness of persons with disabilities in North Carolina.

## **Design**

Michael Brady  
FPG Child Development Institute

## **Illustrations**

The Center for Universal Design, College of Design, North Carolina State University

## **Suggested citation:**

North Carolina Office on Disability and Health (2004). *Removing barriers: Planning meetings that are accessible to all participants*. Chapel Hill: The University of North Carolina, FPG Child Development Institute, NCODH.

5,000 copies of this document were printed at a cost of \$7,280.00, or \$1.46 each.

# Acknowledgments

Planning accessible meetings is not a new concept. Even before the passage of the Americans with Disabilities Act of 1990, materials have explained how to make meetings and conferences accessible to everyone. Ronald L. Mace, FAIA, a disability rights pioneer, wrote the first of these documents emphasizing the importance of planning accessible meetings and conferences. His guide, *The Planner's Guide to Barrier-Free Meetings*, has served as the standard for meeting planning for over twenty years and is the basis for many subsequent materials. Mace coined the term and promoted the concept of Universal Design and founded the Center for Universal Design, part of the College of Design at North Carolina State University. We would like to give Ron Mace and the Center for Universal Design due credit for setting the standard and continuing to raise the bar to make sure everyone has universal access and full participation in meetings and all areas of community life.

We would also like to acknowledge June Isaacson Kailes, disability rights advocate and consultant, who has been at the forefront of the independent living movement and efforts to ensure accessibility for persons with disabilities. She has written extensively on meeting accessibility and her publication, *A Guide to Planning Accessible Meetings*, developed in conjunction with the Independent Living Research Utilization Project at the Institute for Rehabilitation and Research at Baylor College of Medicine, still serves as the essential guide for organizing large meetings and conferences for diverse groups.

## Reviewers

We would like to express our deep appreciation to the following individuals for their time and expertise in reviewing this guide.

Rene Cummins  
Universal Disability Advocates  
Raleigh, NC

Richard Duncan  
The Center for Universal Design  
Raleigh, NC

Karen Hamilton  
NC ADA Network  
Raleigh, NC

June Isaacson Kailes  
Disability Policy Consultant  
Playa del Rey, CA

Renee Wells  
Cultural Access Consultant  
Middlebury, VT

Mary Helen Witten  
Centers for Disease Control and Prevention  
Atlanta, GA

Leslie C. Young  
The Center for Universal Design  
Raleigh, NC

This guide would not have been completed without the significant contribution of the staff of the North Carolina Office on Disability and Health

Lauren Howard  
Cathy Kluttz-Hile  
Karen Luken  
Marcia Roth  
Donna Scandlin



## Contributors

This publication reflects the contributions of many advocates and organizations who have published guidelines to improve the accessibility of meetings and conferences. It represents a compilation of materials submitted to and collected by the North Carolina Office on Disability and Health. We would like to specifically recognize the following sources:

*Accessible Meetings and Conventions*

Association on Higher Education and Disability  
Columbus, OH

*Accessible Meetings in Washington State*

Governor's Committee on Disability Issues and Employment  
Olympia, WA

*Accessible Temporary Events: A Planning Guide*

The Center for Universal Design  
Raleigh, NC

*Checklist for Readily Achievable Barrier Removal*

Adaptive Environments Center, Inc. and Barrier Free Environments, Inc.,  
Boston, MA

*Design for Accessibility: A Cultural Administrators Handbook*

National Endowment for the Arts, National Endowment for the Humanities,  
National Assembly of State Art Agencies,  
the Kennedy Center and MetLife Foundation  
Washington, DC

*A Guide to Planning Accessible Meetings*

ILRU Research and Training Center on Independent Living  
at the Institute for Rehabilitation and Research  
Houston, TX

*The Planner's Guide to Barrier-Free Meetings*

Barrier Free Environments, Inc. and  
Harold Russell Associates, Inc.  
Waltham, MA

*Planning a Great Meeting*

The Robert Wood Johnson Foundation  
Princeton, NJ

*Planning Accessible Conferences and Meetings: An ERIC/OSEP Information Brief for Conference Planners*

Clearinghouse on Disabilities and Gifted Education  
Arlington, VA

*Planning Accessible Meetings: A Guide to ADA Compliance*

American Society of Association Executives  
Washington, DC

**For alternate formats or additional copies contact:**

North Carolina Office on Disability and Health

FPG Child Development Institute

Campus Box 8185, UNC-CH

Chapel Hill, NC 27599-8185

Phone/TTY: 919-843-3531

Fax: 919-966-0862

Email: [odhpubs@mail.fpg.unc.edu](mailto:odhpubs@mail.fpg.unc.edu)

Website: [www.fpg.unc.edu/~ncodh](http://www.fpg.unc.edu/~ncodh)

Whenever possible, NCODH will make information available in alternate formats, such as large print, Braille, audio, and diskette, upon request. Please note that this may not be possible for all publications.

# Table of Contents

|   |           |
|---|-----------|
| Acknowledgments .....   | v         |
| Purpose of This Guide.....  | xi        |
| <b>Planning a Barrier-Free Meeting .....</b>                        | <b>1</b>  |
| Understanding Disability .....                                      | 2         |
| Commitment to Inclusive Meetings.....                               | 4         |
| Including People With Disabilities in Planning and Assessment ..... | 5         |
| Planning a Large Meeting or Conference .....                        | 6         |
| <b>Accessible Meeting Facilities .....</b>                          | <b>7</b>  |
| Standard Accessibility Features.....                                | 7         |
| Determining Accessibility .....                                     | 15        |
| Usable Meeting Rooms.....   | 18        |
| <b>Accessible Presentations .....</b>                               | <b>23</b> |
| Determining What the Audience Needs .....                           | 23        |
| Guidelines for Speakers .....                                       | 25        |
| Readable Presentation Materials for Everyone.....                   | 26        |
| Providing Appropriate Accommodations .....                          | 29        |
| <b>Other Meeting Activities .....</b>                               | <b>30</b> |
| Food Breaks .....   | 30        |
| Off-site Tours .....  | 31        |
| Overnight Stays.....  | 32        |
| <b>Conclusion .....</b>   | <b>34</b> |
| <b>Appendix .....</b>   | <b>35</b> |
| Accessible Meetings Resources .....                                 | 35        |
| Accessible Meetings Checklist .....                                 | 45        |



# Purpose of This Guide

This publication highlights basic guidelines and strategies to help organizations make their meetings accessible and welcoming to people with disabilities. The guide focuses on small and last-minute meetings to make sure that a variety of participants are included in all aspects of organizational life.

An environment that is accessible, functional, and safe benefits everyone, regardless of age or level of ability. This principle, known as Universal Design, serves as the basis for the information presented in this publication. The guide describes the benefits of providing both physical and communication access.

Creating accessible environments involves a great deal of attention to detail. Yet it is important to note that this guide is not designed to be exhaustive and therefore cannot provide all the specifications that might be needed to ensure full access. However, in an effort to provide this information, the guide does include resources, illustrations and a checklist to aid meeting planners in creating an inclusive event.



# Planning a Barrier-Free Meeting

Every organization has meetings. Whether they are committee meetings, task force meetings, training sessions, workshops, public forums or other kinds of gatherings, they occur often, at times without much advance notice. Planners are faced with the challenge of creating a productive meeting in a comfortable environment without always knowing who will attend and whether one or more participants will have difficulty hearing, seeing, or moving, or have any other disability. With a little pre-planning, awareness, and willingness to consider the possible needs of a variety of participants, the host can make any meeting a usable and comfortable environment for everyone.

Knowing where to start can be the biggest obstacle, especially if one is not familiar with accessibility issues or the needs of individuals with various disabilities. **Creating a barrier-free meeting requires a degree of flexibility and willingness to make last-minute changes to any aspect of the meeting.** By treating each meeting as though someone with a disability might attend, one can begin to eliminate barriers to full participation and create an improved environment for everyone.

When planning a meeting, some basic issues are vital to ensure that the meeting is accessible to people with disabilities. This guide will address each of the following issues in greater detail:

1. The facility where the meeting will be held should meet basic standards, set forth by the Americans with Disabilities Act, that enable people with a variety of disabilities to move around without physical barriers. See pages 7–17.
2. The meeting room itself should be accessible, including seating, to allow access for participants with sensory, physical, and communication disabilities. See pages 18–22.
3. Information should be presented in such a way that is easily understood by individuals with a variety of abilities. See pages 23–29.
4. Participants should be given the opportunity to request accommodations (e.g., large print, assistive listening devices, interpreters) that they might need to participate in the meeting and planners should make every effort to fulfill those requests. See pages 23–29.

5. All meeting activities such as breaks, off-site tours, social activities, etc. should be accessible to ensure that everyone is an active participant. See pages 30–31.

### **Tips for Interacting with People with Various Disabilities**

- Always treat anyone with a disability with the same respect that you would extend to everyone else.
- Use words that put the person first, referring to them as a “person with a disability” or “person with hearing loss.” Do not use words like “handicapped,” “retarded,” “crippled,” or “wheelchair bound.”
- Don’t be afraid to offer assistance to a person with a disability, but wait until the offer is accepted before you help. Listen to any instructions that the individual gives about the best way to assist them.
- When talking with a person who has a disability, speak directly to them rather than to a companion or interpreter who may be with them.
- Speak in a normal voice. Do not shout unless someone has indicated that they are hard of hearing and prefer this method of communication.
- As with anyone else, let a person with a disability make their own decisions regarding what they can or cannot do. Be careful not to be overprotective.
- Be considerate of the extra time it may take some people with disabilities to complete a task or get somewhere.

## **Understanding Disability**

As participants, people with various disabilities have the same desires to be involved and included. The fact is that almost everyone is likely to experience a temporary or permanent disability at some point in his or her life. Anyone can be born with a disability, acquire a disability through an illness, chronic disease or injury, or get older and lose some of the abilities of their youth. **When you consider having a disability as a universal experience, being prepared to accommodate anyone with a disability constitutes good customer service.**

Disabilities can vary widely in terms of type, severity, and duration, but it is helpful to understand some general characteristics. People can experience



disabilities that affect their mobility, sight, hearing, understanding, and speech. The following statements are intended to raise a level of awareness and do not account for the individual nature of each person's disability or experience.

- Mobility disabilities are the most widely recognized because of the visible use of aids such as a wheelchair, scooter, or cane. It is important to consider that mobility limitations can also affect stamina, balance, and ability to reach or grasp.
- Cognitive disabilities may affect understanding, communication, or behavior and can be attributed to brain injuries, developmental or learning disabilities.
- Some disabilities may not be obvious, including chronic conditions such as asthma, heart disease, or seizures. Many cognitive, learning, or psychiatric disabilities may also not be apparent.
- People with speech disabilities may use an alternate means of communication such as an assistive device to speak for them. A speech disability often has no impact on a person's ability to understand.
- There are varying degrees of vision loss and a distinction between blindness and low vision. Some people can distinguish between light and dark, or between contrasting colors, or read large print, but have difficulty with small print or low-light situations. They may use a cane or service animal to help with orientation and movement in an environment.
- Hearing loss varies. People who are Deaf or hard of hearing use different ways to enhance communication, including hearing aids, speech reading, or sign language. They may also require the use of a text telephone, called a TTY, and may use other aids such as captioning or assistive listening devices.
- People with environmental disabilities or multiple chemical sensitivities can have a physical or cognitive reaction to a chemical or combination of chemicals such as pesticides, deodorizers, smoke, or perfumes, which may affect their ability to breathe or process information.

## Commitment to Inclusive Meetings

An organizational commitment to planning accessible meetings often begins with a statement or policy. An accessibility policy for meetings shows that your organization welcomes everyone and has planned ahead in an attempt to meet the needs of all participants who may attend a meeting or event.

All meeting announcements should include a reference to the commitment of the organization and meeting planners to provide an accessible location and accommodations upon request.

For example, if an organization is housed in an inaccessible building, then a commitment to accessibility requires that meetings be held at an alternate, accessible site. Policies should also set standards for providing accommodations to participants, such as interpreters or alternate formats.

### Sample Policy Statements

[Name of organization] is committed to providing equal access in all aspects of business, including meetings and events hosted and endorsed by this organization. Those responsible for planning a meeting or event will ensure that meeting sites are accessible to people with disabilities and meet basic requirements according to the ADA. It is also the responsibility of meeting planners to provide accommodations to ensure accessible communication.

Adapted from US Department of Education Policy Statement on Meeting Accessibility.

[Name of organization] will not hold any meeting where the facility has known barriers which exclude people with disabilities from attending and participating.

Adapted from *A Guide to Planning Accessible Meetings*.

## Including People With Disabilities in Planning and Assessment

The involvement of persons with disabilities is important when planning a meeting and when assessing the accessibility of a meeting site. They can often identify barriers or issues that those without the experience of living with a disability can overlook. It is important that people with disabilities be knowledgeable about cross-disability access issues, taking into account persons who have hearing, vision, mobility, speech, and cognitive limitations. These individuals need to be knowledgeable about a variety of physical and communication access issues and not just speak to their own needs. (Adapted from *Emergency Evacuation Preparedness Guide for People With Disabilities and Other Activity Limitations*.)

If you do not know anyone with a disability or with knowledge of accessibility issues, you can contact a disability-related organization, such as a local Center for Independent Living or local chapters of UCP (United Cerebral Palsy), Easter Seals, the Multiple Sclerosis Society, or the Arc. Look in the phone book for local chapters and other disability organizations in your area. It is important that an organization is knowledgeable about the ADA and equipped to assess for accessibility. Not all disability organizations are equally prepared. (Adapted from *A Guide to Planning Accessible Meetings*.)

## Planning a Large Meeting or Conference

Although this guide is designed to focus on small meetings, many of the same principles apply to large meetings and conferences. When planning larger meetings or multi-day conferences, there are other issues that need to be addressed to accommodate people with disabilities. It is more likely that a larger conference or meeting will have more than one or two participants who have a disability, and planners may need to provide a variety of accommodations. Because this guide does not include the necessary detail for larger meetings it is important to consult other resources.

### *A Guide to Planning Accessible Meetings*

June Isaacson Kailes and Darrell Jones

ILRU Research and Training Center on Independent Living  
at the Institute for Rehabilitation and Research

2323 S. Shepherd, Suite 1000

Houston, TX 77019

(713) 520-0232 (Voice)

(713) 520-5136 (TTY)

(713) 520-5785 (Fax)

[ilru@ilru.org](mailto:ilru@ilru.org)

[www.ilru.org](http://www.ilru.org)

# Accessible Meeting Facilities

The Americans with Disabilities Act of 1990 (ADA) is a civil rights law that prohibits discrimination against anyone who has a disability. It sets forth minimum requirements for accessibility of facilities to ensure that anyone with a disability has the same access to programs and services, public accommodations, employment, transportation, and telecommunication. The ADA requires the removal of physical and communication barriers so everyone with a disability has the same opportunity to participate. While there is no way to explain all aspects of this law within the scope of this guide, it is important to consider the spirit in which this law was written and make every effort to remove barriers and prevent discrimination.

## Standard Accessibility Features

The ADA specifies how buildings and facilities must be designed or modified in order to be accessible by following the guidelines known as ADA Standards for Accessible Design, also known as ADA Accessibility Guidelines (ADAAG). Although not every feature providing access to people with disabilities is discussed in detail here, those with particular relevance to meetings are addressed. For specific information on positions, dimensions, and/or clearance guidelines for each accessibility feature, refer to the ADA Standards for Accessible Design or ADA resources found in the Appendix. The Accessible Meetings Checklist in the Appendix (pages 45–52) includes other accessibility features that are not mentioned in the following section, but are no less important.

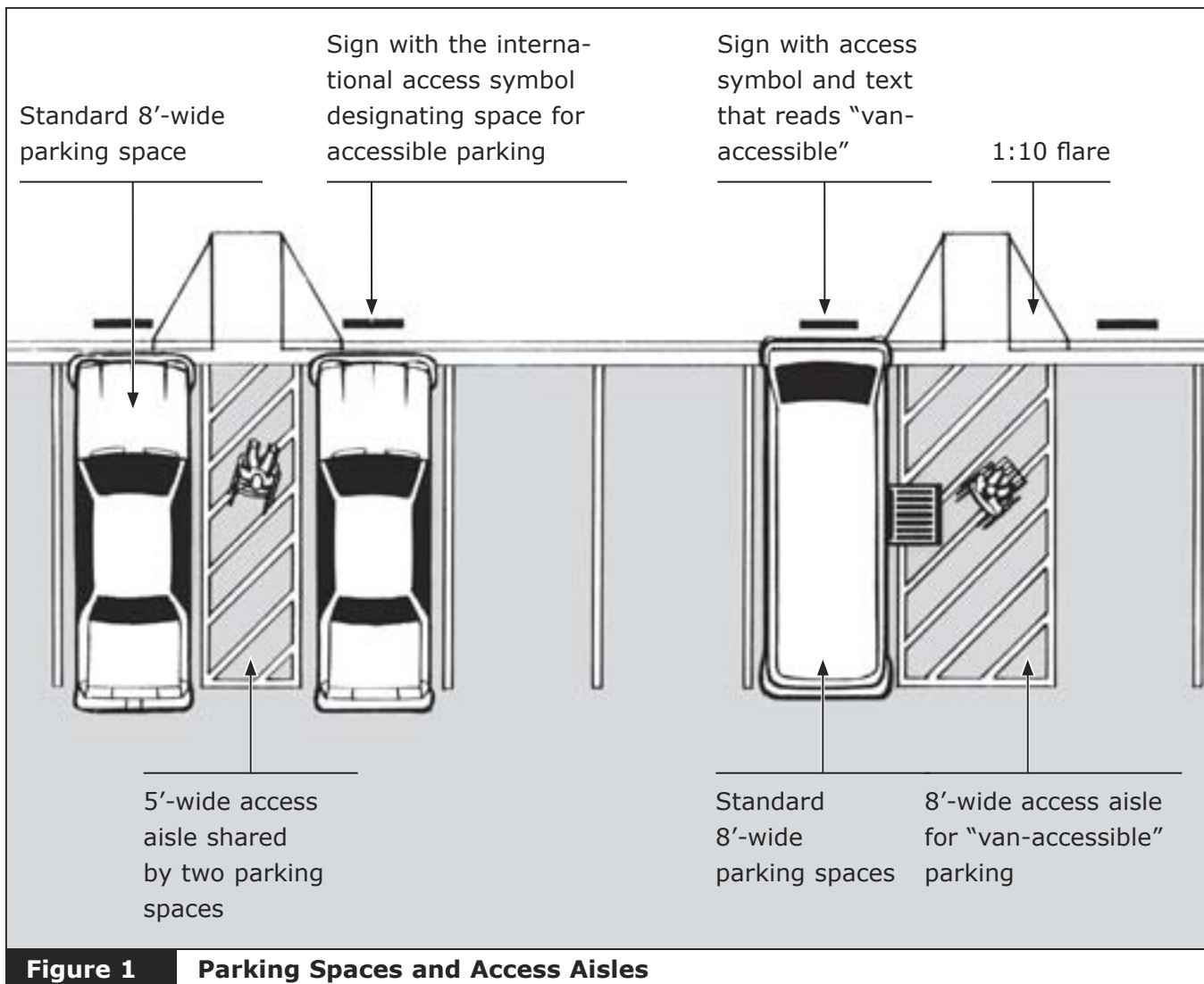

### Entrances / Parking

A facility used for any size meeting should have a primary entrance that allows people with disabilities to approach and enter the building in the same manner as everyone else. (See Figures 1, 2, and 3.) For more information on the required number of parking spaces, see the Accessible Meetings Checklist in the Appendix (pages 45–52) or the ADA guidelines.

- Accessible parking spaces should be 8' wide with 5' wide aisles and close to the entrance. Van-accessible spaces should be 8' wide with 8' wide aisle.

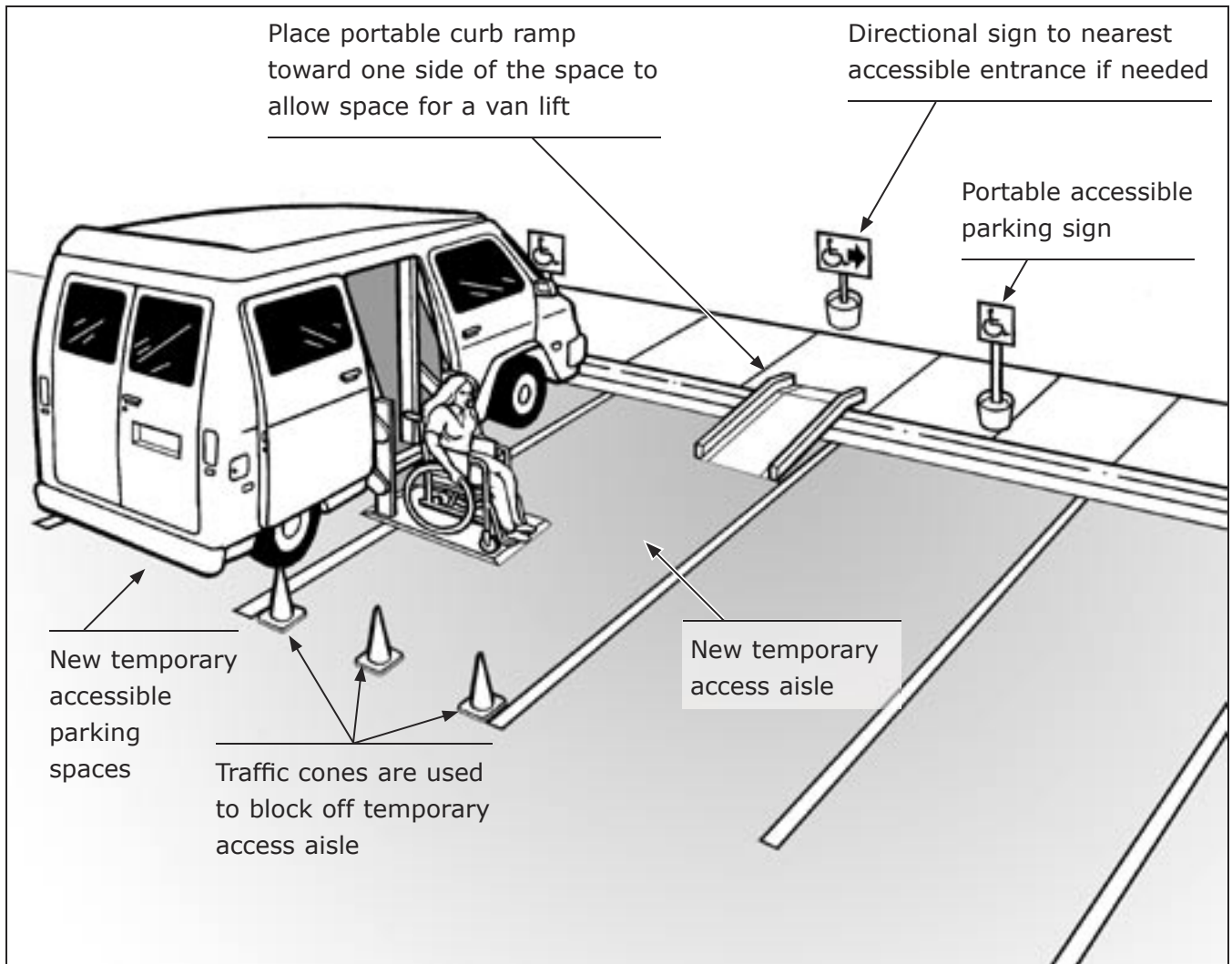
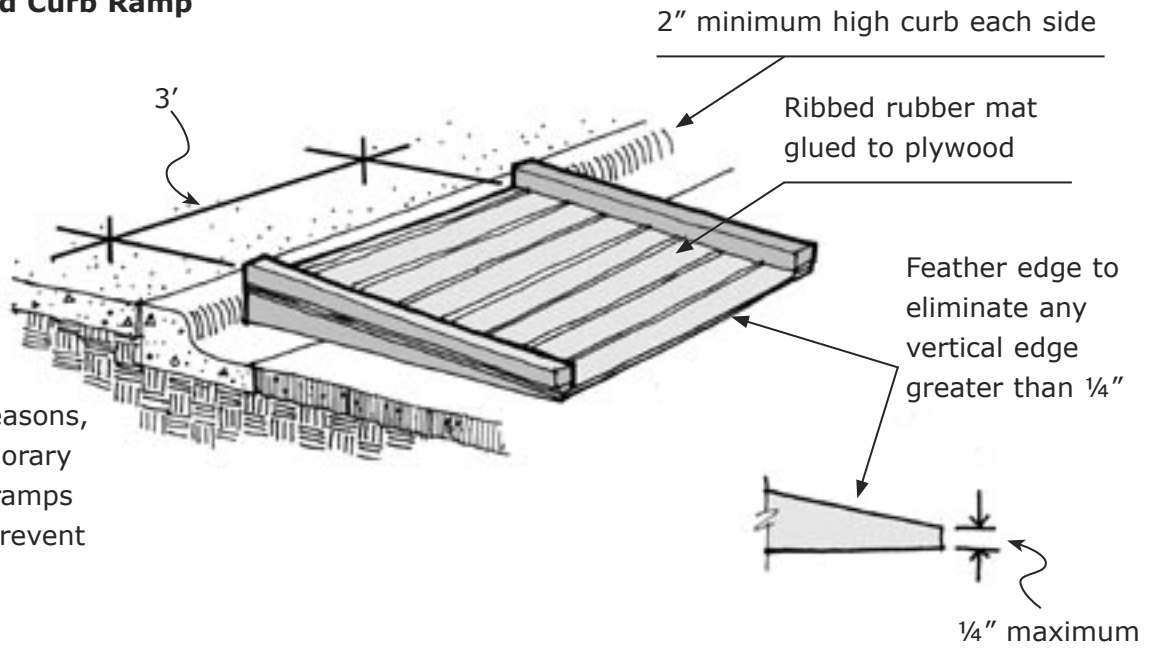

**Figure 2** Temporary Modifications to Create Accessible Parking Spaces

- Primary entrance should be accessible and not require the use of stairs.
- All sidewalks should have curb cuts at locations near parking and along the route to the primary entrance.
- An exterior door that provides at least 32" wide clear opening and a low threshold.
- An exterior door that is easy to open (5 lbs. of force or less) with lever or loop-type handles, or that has a power door opener.

**Temporary Wood Curb Ramp**

For safety reasons, anchor temporary or portable ramps in place to prevent slippage.



**Manufactured Portable Curb Ramp**

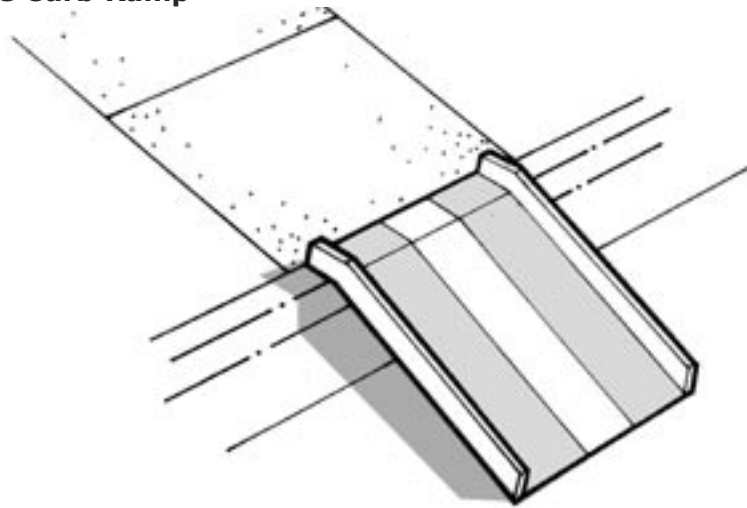

**Typical Flared Curb Ramp Used in New Construction**

Flare can be as steep as 1 in 10, if out of pedestrian path of travel

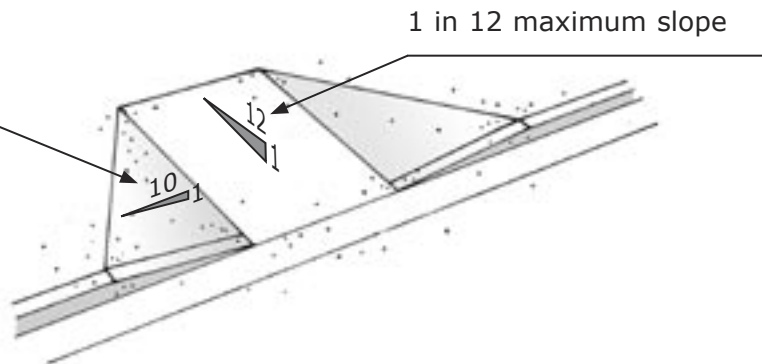

**Figure 3** Curb Ramps



**Route of Travel**

A route of travel can involve any area inside or outside a building that someone may have to go around or through, connecting all spaces such as parking, entrances, meeting rooms, restrooms, telephones, and any other facility or service.

- An accessible route of travel should not require the use of stairs and be at least 36" wide with at least 60" clear space for turning.
- The surfaces should be level, firm and slip resistant.
- Areas should be free from protruding (maximum of 4") or low hanging items (higher than 27").
- All interior doors should be at least 32" wide.

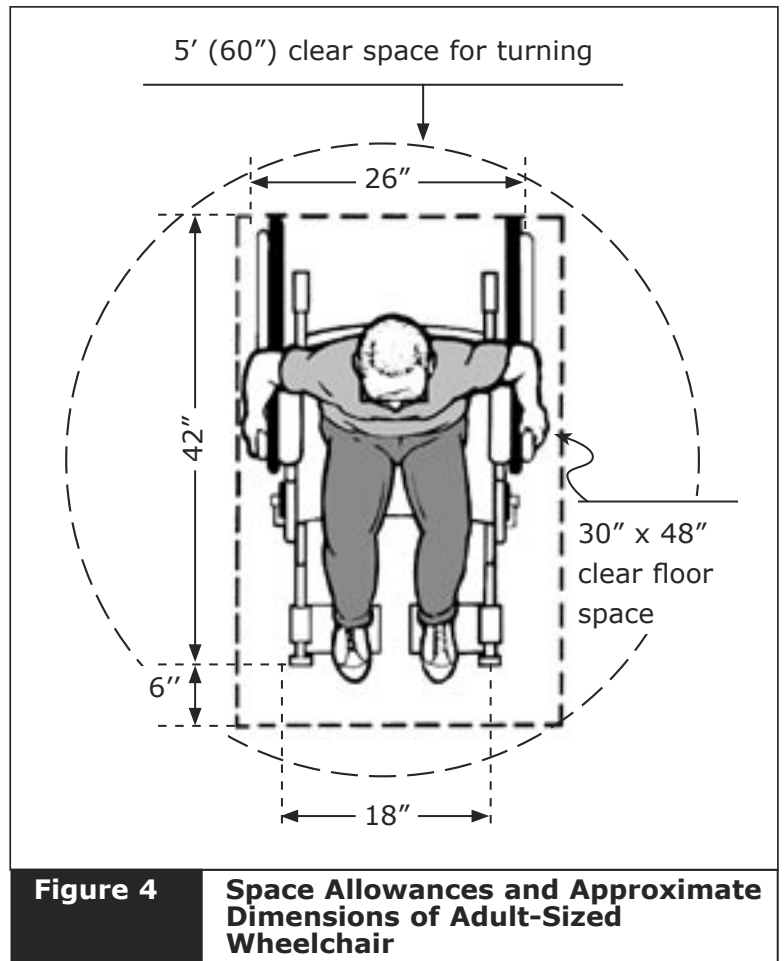

**Figure 4** Space Allowances and Approximate Dimensions of Adult-Sized Wheelchair

**Elevators/Ramps**

It is vital that participants have access to all levels and areas of a building that are connected by stairs and used as part of the meetings.

- At least one passenger elevator should be available in buildings over one story if an upper floor is used for the meeting or amenities that support the meeting, e.g., restrooms.
- Elevators should contain both visible and verbal or audible signals, and controls should have raised and Braille lettering.
- Ramps should have a maximum slope of 1:12 (1" of rise for every 12" of run) and have a level landing at the top and bottom.

## **Signage**

Directing people to all areas of a facility is an important part of an accessible environment. Signs using the international symbol of accessibility should be used to designate key areas such as accessible parking, entrances, and restrooms.

- Signs should be mounted on the wall adjacent to the opening at a height of 60”.
- Key directional signs (restrooms, exits, etc.) should contain raised (tactile) and Braille lettering.
- Characters and symbols that have high contrast with their background (i.e., dark letters on a light background or light letters on a dark background) are easier for everyone to read.

The Graphics Artists Guild Foundation has developed and made available 12 symbols that can be used to indicate accessible places or programs for people with various disabilities. These can be downloaded from their web site (see Appendix, page 41).

## **Restrooms**

There should be at least one accessible restroom in any facility that is used for a meeting. Restrooms that are not accessible are one of the most common problems with planning a meeting, so it is important to pay attention to the following features. (See Figures 5, 6, and 7.)

- Accessible restrooms should have a stall large enough to maneuver a wheelchair or other mobility devices (at least 5' x 5').
- The door into the stall should be at least 32”, and swing outward with an easy-to-operate latch. Try operating the latch with a closed fist to determine ease of operation.
- The stall should contain grab bars and the toilet seat should be 17” to 19” from the ground.
- The sink should have clear space below with 30” knee clearance to allow someone in a wheelchair to roll under.

- Dispensers, including soap, paper towel, and hand dryers, should be within 48" of seated users or people who are shorter.
- Pathways in the restroom should be at least 36" wide and allow room to maneuver.

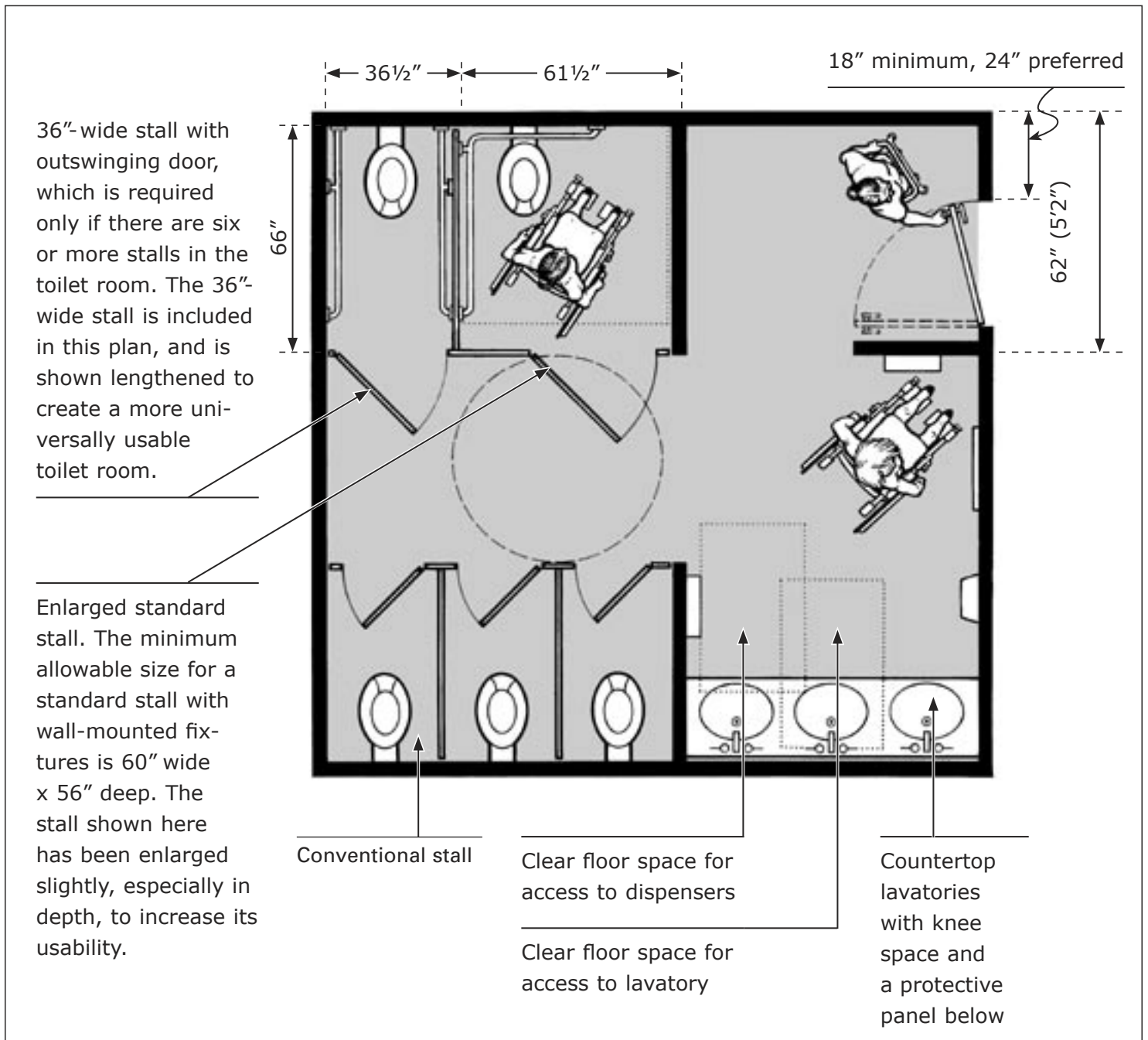

**Figure 5** Layout of Small Universal Toilet Room

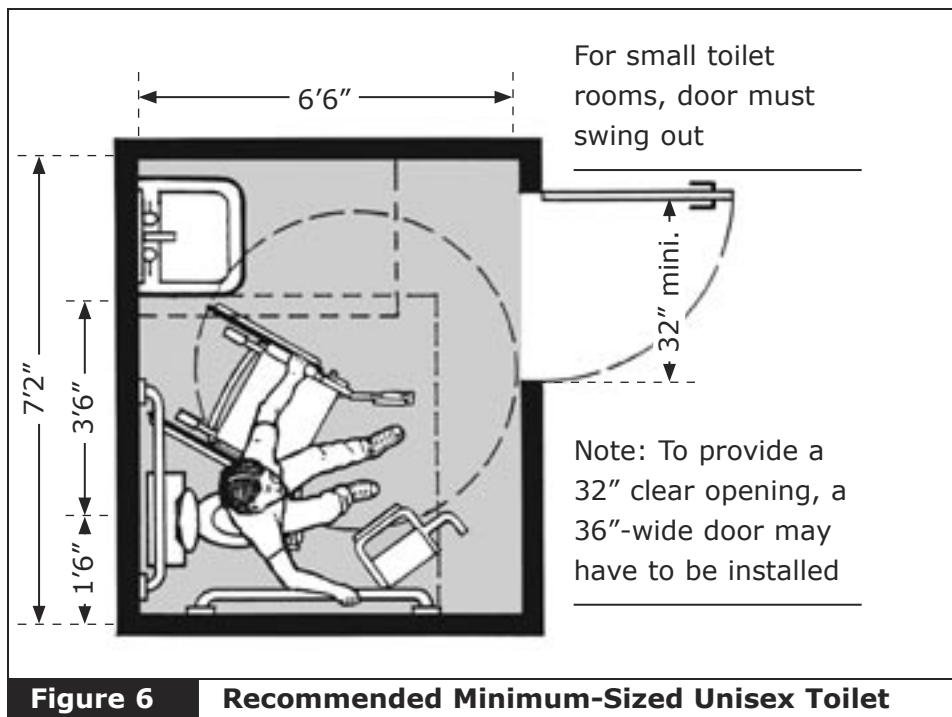

### Emergency Procedures

Providing proper notification and means of escape in an emergency is required as an accessibility feature. If the meeting is located above the first floor of a multi-level building, planners should have an emergency evacuation plan to assist someone who cannot use stairs when the elevator is shut off. If there is a designated "place of refuge" or fireproof room, make sure that participants with a disability know where to go in case of an emergency. For a more detailed explanation of requirements to ensure proper emergency procedures, consult resources listed in the Appendix.

- There should be an accessible route of travel to the emergency exit.
- Audible and visible alarms must be present in any facility to alert individuals of an emergency.
- Manual fire alarms or fire extinguishers need to be within reach of wheelchair users (no more than 54" above the floor).

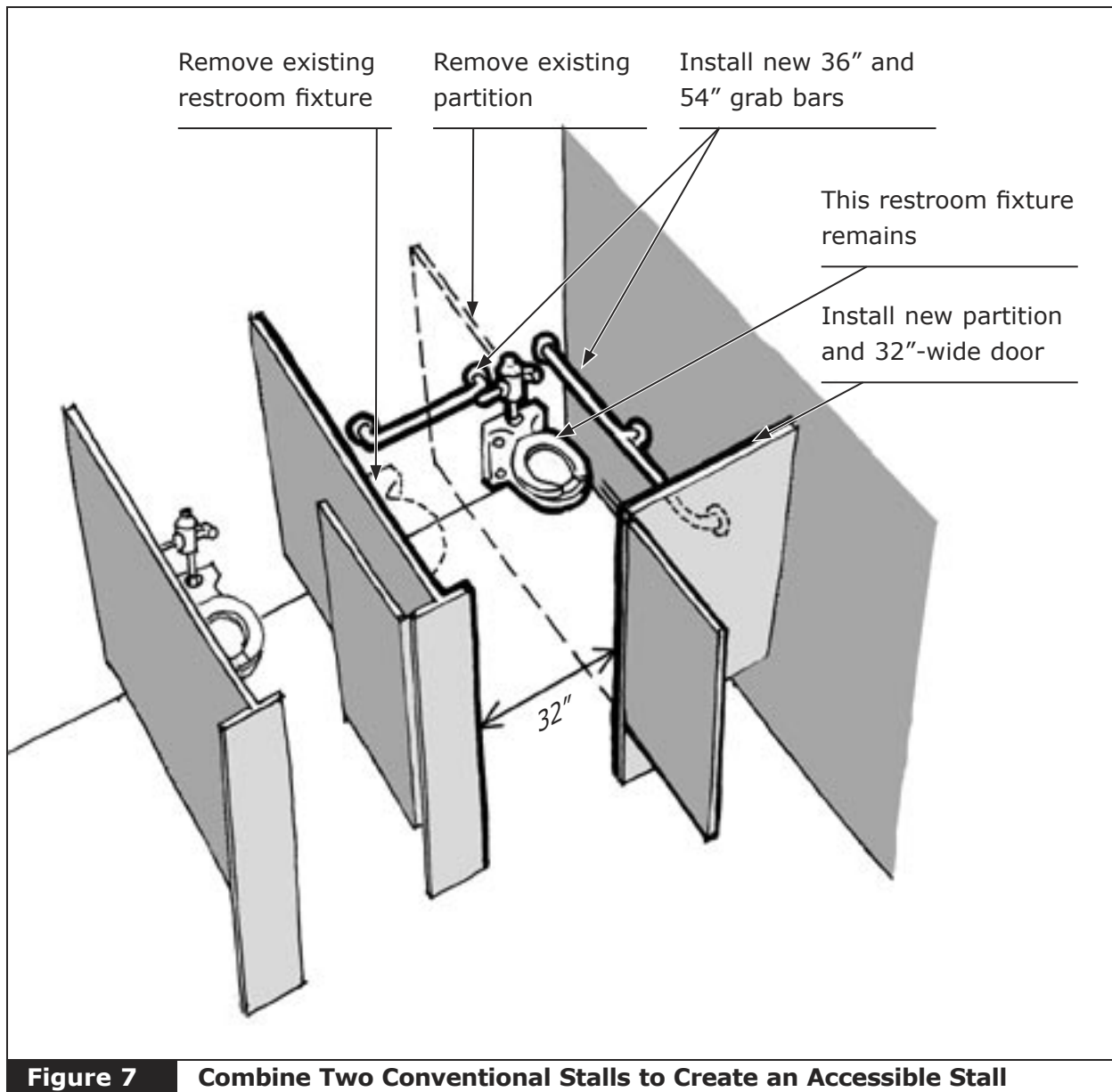

## Determining Accessibility

If meetings are held in your organization's own facilities, it is important that you carefully assess the environment. It is easy to overlook barriers in your own building. If a meeting will be held in an outside location, it is equally vital that you visit the site to determine accessibility. Even if facility personnel state that a site is accessible, never assume it is an accurate assessment. If a facility has steps without a ramp, multiple levels without an elevator, no accessible stall in the restrooms, you need to look elsewhere for a meeting site.

It is helpful to use a checklist when visiting a site or assessing your own facility to make sure that important features are not overlooked. It is likely that a facility will not meet every requirement on a checklist, but it is important that it meets minimum standards required by the ADA. A sample checklist is included in the Appendix.

If after a careful assessment of the site, you determine that there are some barriers that would make participation difficult, it is important to bring this to the attention of facility management. It is helpful in this situation to be aware of resources that can offer benefits, including tax benefits, and can remove barriers to improving accessibility. For more information on specific guidelines for barrier removal, contact your regional ADA technical assistance center, also called Disability Business Technical Assistance Centers (DBTAC). Other resources are located in the Appendix. It is best to negotiate with a facility to find permanent solutions to barriers.

### **The Last Minute Double-Check**

Even with the greatest effort to ensure an accessible facility, it is often the case that barriers can be overlooked. Make sure to allow some time before participants arrive to identify possible obstacles. Here are some common problems:

- Vehicles, especially delivery trucks, blocking the ramp or curb cut onto the sidewalk
- Items blocking the hallway or accessible routes, including low-hanging or protruding objects
- Trash cans in front of elevator buttons
- Trash cans in front of paper towel dispenser in restrooms
- Slippery or wet floors
- Bumps or steps greater than ½"
- Snow, ice, or wet leaves on sidewalks or curb cuts
- Standing water near an entrance

## Temporary Modifications

If a permanent solution is not possible before a meeting or event, there are temporary measures that can help remove barriers and make facilities or meeting spaces more accessible. While temporary measures are not as effective and usable as a permanent solution, they show a commitment to accommodate all participants.

- If additional accessible parking spaces are needed, tape can be used to re-stripe the parking area. Signs must also designate these temporary spaces. (See Figure 2 on page 9.)
- Ramps onto curbs, over thresholds, and up one to two stairs can often be made with portable ramps that can be rented from medical equipment vendors. Make sure that any temporary ramp is secured, has a non-slip surface, and meets the 1:12 slope requirements. (See Figure 3 on page 10.)
- Temporary signs can be created to designate accessible restrooms. Braille and other tactile signs can be added to doors and elevator panels.
- Paper cups can be placed next to an inaccessible water fountain.
- If a pay phone with TTY access is not available, a text telephone can be placed at the registration desk or other central location. Signs should be added to direct people to the accessible phone.
- A 5' x 5' wheelchair-accessible toilet stall should be provided. If a restroom stall is too narrow for a wheelchair user to fit and allow the door to close, the door can be removed and a curtain used for privacy. If this space is still too small, remove the divider between two toilet stalls to make more room. (See Figure 7 on page 15.)

It is important to note that temporary measures to address accessibility should never become an acceptable end goal. Once a barrier is identified, steps should be made to remove the barrier permanently. (Adapted from *Accessible Temporary Events*.)

### Community Meeting Sites That Are Often Accessible

- Library
- Parks and Recreation Center
- Senior Center
- Community College
- Hospital classrooms/Boardroom
- Newer buildings

## Usable Meeting Rooms

Space is the biggest consideration when evaluating the accessibility of a meeting room. Meeting rooms often seem cramped for space, especially when last-minute or unexpected participants arrive. It is important to allow more room for participants who may use a wheelchair, crutches, scooter, service animal, or sign language interpreter. Arranging for a slightly larger than needed room often results in a more comfortable environment for everyone and allows for greater flexibility when accommodating participants with a disability. (See Figures 8, 9, and 10.)

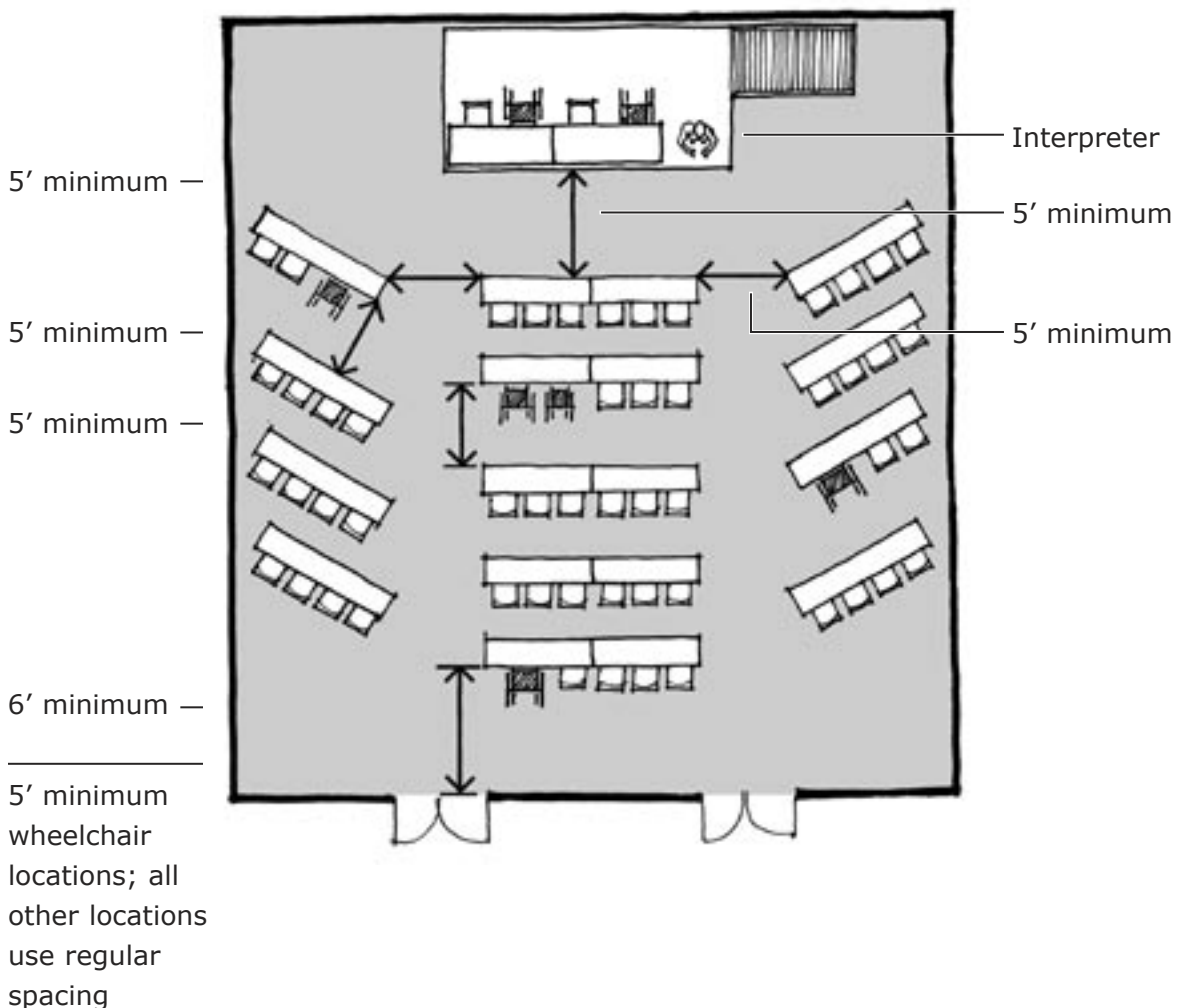

**Figure 8** Classroom-Style Plan (with loose tables and chairs)



### Seating Arrangements

All participants should be able to maneuver throughout the room, sit where they are comfortable and with whom they choose, see and hear the presentation, and be part of the conversation and activities. (See Figures 9 and 10.) Although the meeting, room set-up, and seating options may be different in each facility, there are some basic considerations that can increase accessibility:

- People who use mobility aids such as wheelchairs or walkers should have multiple options regarding seating, instead of being limited to the back or front of the room. It is important to allow choice.
- Aisles should be at least 33" wide, but 44" is recommended.
- Make sure to have seats reserved in the front of the room for participants with seeing or hearing disabilities who may be more comfortable in the front.

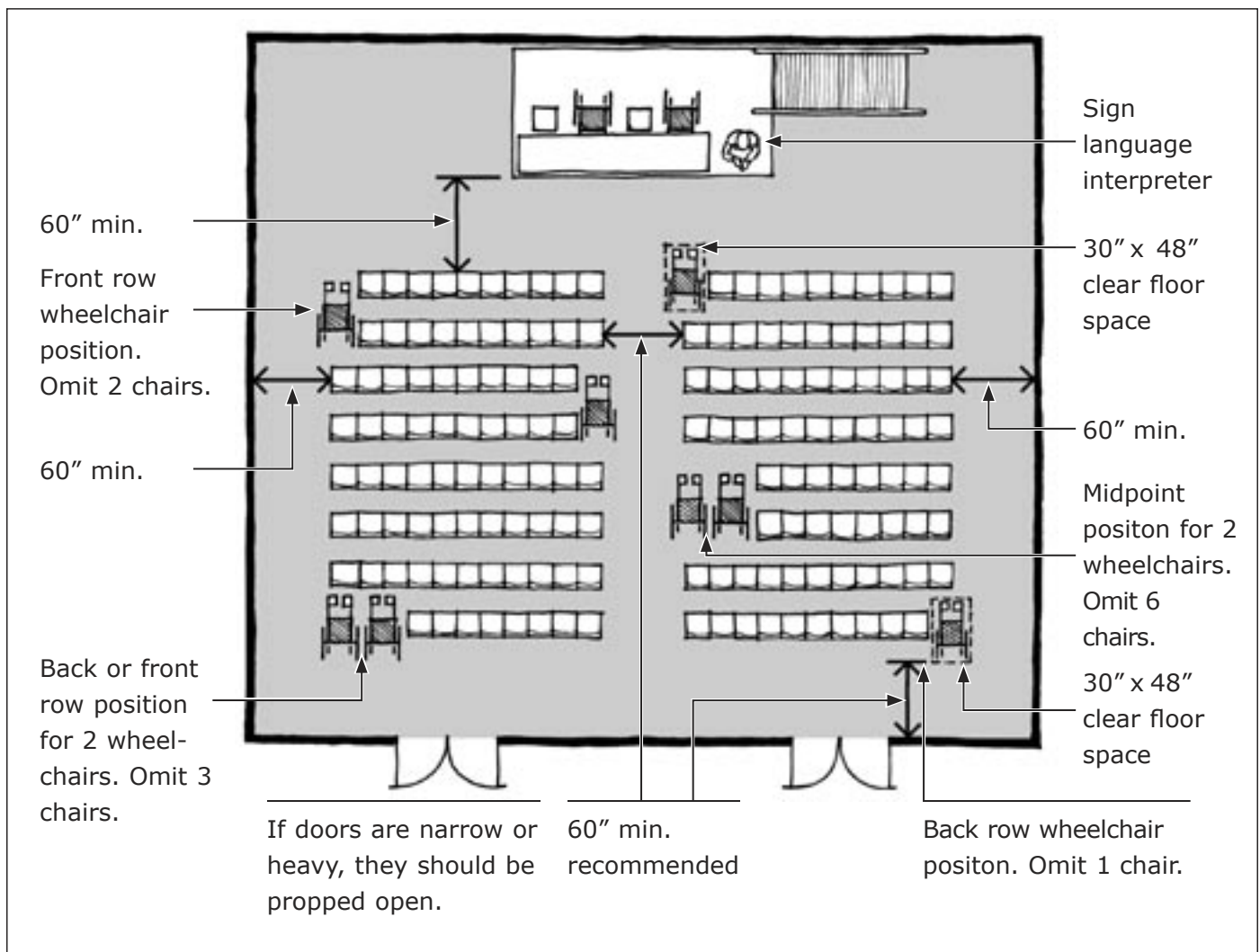

**Figure 9 Theater-Style Plan (with movable seating)**

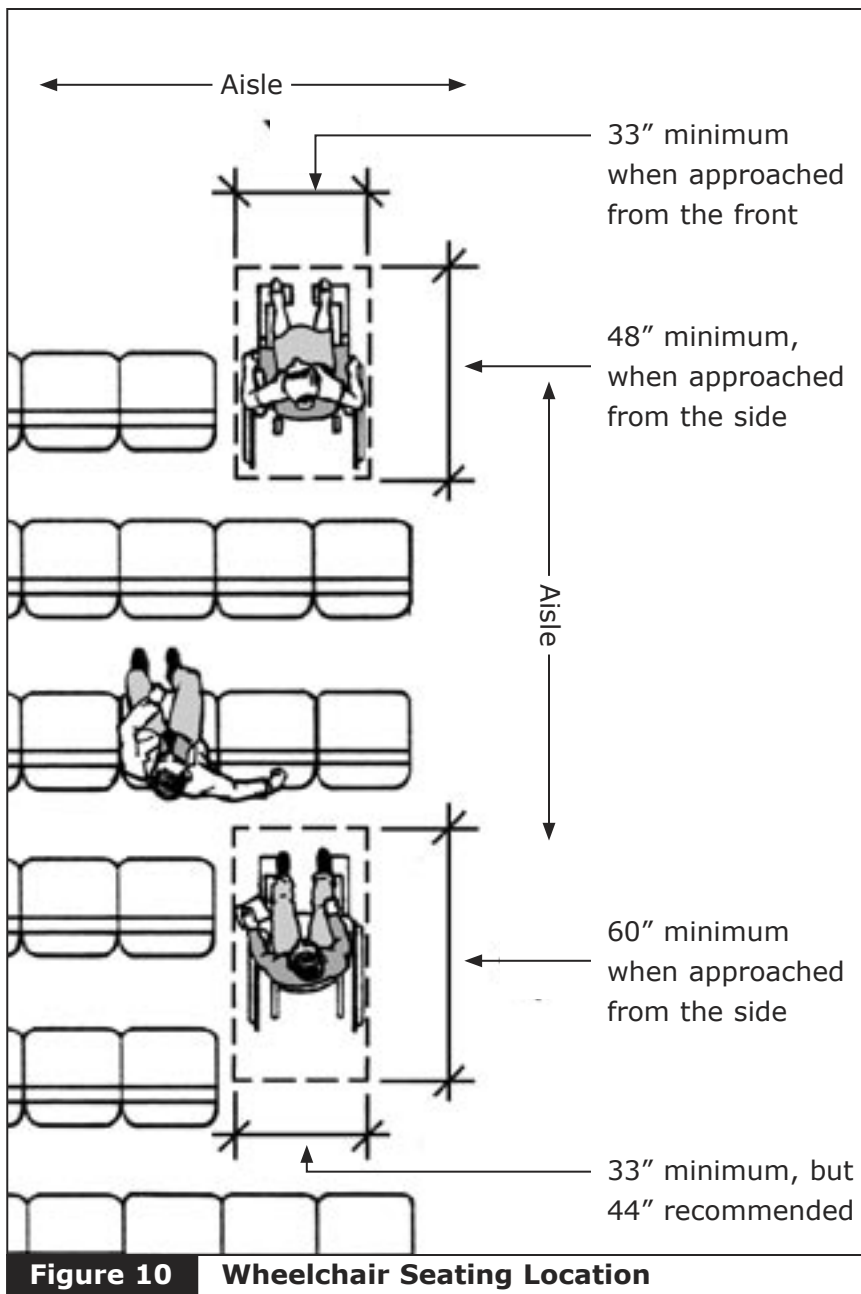

- If tables are used, at least a 27" clearance is required between the floor and table apron. If more knee clearance is needed, then books or blocks can be placed under table legs.
- Outlets may be needed if participants are using assistive listening devices or computers. Be sure to have extension cords and tape on hand.
- If a sign language interpreter is used, it is important that they sit close to the speaker and participants and have appropriate lighting.
- People with disabilities who rely on assistance may bring a personal attendant or service animal with them to a meeting. Meeting planners should be prepared to provide extra seating and meals for personal attendants and designated areas for service animals to relieve themselves.

### Rooms With Fixed Seating

An environment that allows for flexible room set-up to accommodate anyone with a disability is the best option, but meetings are sometimes held in auditoriums and boardrooms where seating arrangements cannot be changed. An auditorium with fixed seats can be used if there are spaces at the front, side, or rear with a level floor and clear space to allow someone who uses a wheelchair or other mobility device to

sit comfortably. Dispersed seating is always best because it allows people with disabilities to sit where and with whom they wish. Companion seats should be available with these spaces. Auditoriums with stairs or lack of accessible seating at the front or rear should not be used.

Conference rooms or boardrooms used for smaller meetings may contain large heavy tables and chairs that are difficult to move and do not allow someone to move easily around the room. If this is the case, it is important to assess whether it is appropriate to hold the meeting in such a room. If this is the only option for a meeting space and it is used regularly, then it might be appropriate to look into purchasing new furniture that can allow more flexibility in the room's set-up and can be easily reconfigured to accommodate persons with disabilities.

### **Speakers Platform**

It is important that any speaking area be accessible. Creating an accessible environment for the presenter demonstrates a commitment to access and prevents any surprises if the presenter does have a disability. If a raised platform is used for the presenters, it should be equipped with a ramp and handrails. The platform itself should be large enough for a wheelchair user to maneuver and still allow room for a sign language interpreter. The ramp should meet ADA requirements for slope (1:12). Presenters should have the option of a podium or table to use during a presentation. In some small meetings, a table or podium may replace a platform. A presenter should have the option to speak from whatever location in the room they are most comfortable. (See Figure 11.)

### **Other Meeting Room Features**

#### **Lighting**

Many people with low vision require adequate levels of light in a meeting room. Some people with low vision are light sensitive and need less light. Always ask about the comfort level for each individual.

Lighting is also important if a sign language interpreter is used. If lights are dimmed for an audio-visual presentation, make sure that the interpreter has a spotlight to allow the participant to see the interpreter's hands and face.

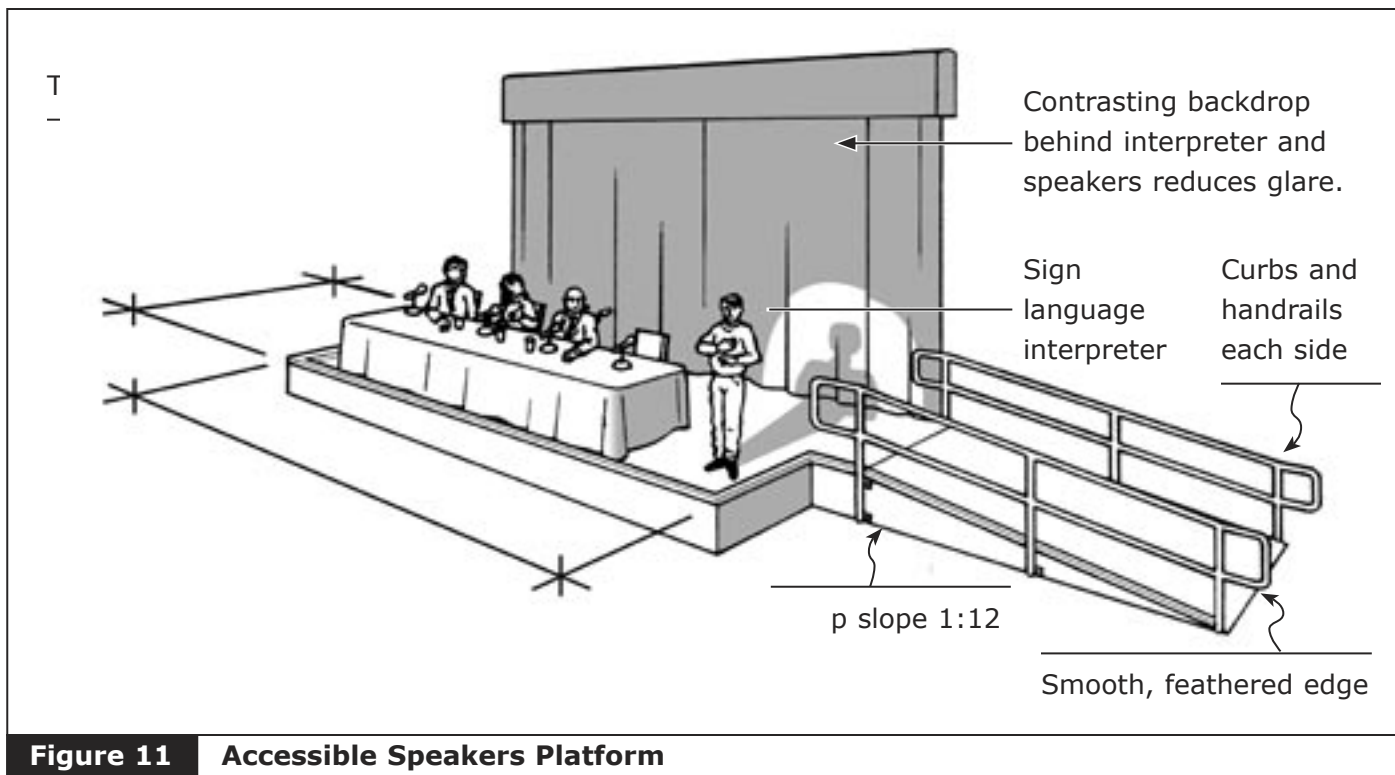

**Figure 11** Accessible Speakers Platform

### Microphones

Microphones should be used, even in a small room, to ensure that no one has to strain to hear a speaker. If the participants ask questions during a presentation or contribute to a discussion, a microphone should be available to the audience. Cordless microphones work best. If a microphone is set up in an aisle, make sure it does not impede traffic. If the presenter has a disability, it is important to give him or her the option of which microphone to use.

### Sound Systems

The quality of the sound system should be evaluated before the meeting in order to make any necessary adjustments. Sometimes older systems and those of poor quality can produce extraneous noises or feedback that is amplified by hearing aids. It may be necessary to replace the system or rent appropriate equipment. Sound systems should also include assistive listening devices for persons who are hard of hearing. If a sound system is being rented, ask for the assistive listening device to use with that system.

## Accessible Presentations

In addition to physical access, it is important to provide accessible presentations. This involves effective communication and providing appropriate accommodations based on the needs of meeting participants. Accommodations can include alternate formats for written materials, such as large print, material on disk, or Braille; or auxiliary aids and services, such as assistive listening devices or interpreters for individuals who are Deaf or hard of hearing. Effective communication and accommodations allow persons with disabilities that affect their hearing, vision, speech, and cognition to participate in all meeting activities. Keep in mind the following five steps to achieve effective communication:

1. Understand that there is not a “one-size-fits-all” solution.
2. Explore ways to accommodate the diverse needs of your audience.
3. Be prepared to offer and respond to requests for materials in alternate formats. See page 26–27.
4. Become knowledgeable about auxiliary aids and other accommodations that may be needed. See page 27–29.
5. Provide ways for participants to make communication needs known to meeting planners. (Adapted from *Design for Accessibility*.)

### Determining What the Audience Needs

If a meeting is planned in advance, registration forms can be a good way to assess the needs of your participants. People with disabilities may have a variety of individual needs that can't always be predicted and some accommodations, such as sign language interpreters, require advance notice. Even small meetings can benefit from some kind of registration or RSVP process that includes a simple question to determine accommodation needs. This demonstrates a commitment to accommodating participants and encourages communication. For some meetings it may be best to list possible accommodations, as noted in the second sample statement.

**Sample Statement**

If you have a disability and may require accommodations in order to fully participate, please indicate here\_\_\_\_\_.

Would you like to be contacted to discuss your needs? \_\_\_\_\_

How would you like to be contacted? \_\_\_\_\_

**Sample Accommodation List for Registration Forms**

I will need the following accommodations in order to participate:

- Interpreter. Type:\_\_\_\_\_
- Note taker
- Assistive listening device
- Open captioning
- Large print. Font size:\_\_\_\_\_
- Braille
- Audio cassette
- Disk. List format:\_\_\_\_\_
- Wheelchair access
- Orientation to facility
- Dietary restrictions. List:\_\_\_\_\_
- Accessible transportation

An assistant will be accompanying me. \_\_\_Yes \_\_\_No

(Adapted from *A Guide to Planning Accessible Meetings.*)

## Guidelines for Speakers

In many cases a speaker will not know who is in the audience and how he or she might need to adapt a presentation for individual participants. There are general considerations that speakers should be made aware of to make sure that the information presented is clear to as many participants as possible. In the case of smaller or more informal meetings, the speaker may know some participants or interact differently depending on the environment. This informal or interactive meeting can mean that some of the accommodations that make a presentation easier to understand by some people with disabilities can be lost. It is important to ensure that speakers understand what is expected. Speakers should:

- Use a microphone during the presentation. This is particularly important for persons who may be using assistive listening devices that feed off a sound system.
- Before answering any questions, repeat the question into the microphone.
- Provide verbal descriptions of any overheads, slides, or charts, reading all text on the visual aids.
- Face the audience when speaking and keep hands or other objects away from the mouth.
- Refrain from speaking too quickly.
- Ensure all visual aids, such as slides and overheads, are printed in as large a font as possible and contain fewer than eight lines of text. Make large print hard copies of slides and overheads available for persons with low vision.
- Present key points in multiple ways, including visual, auditory, and tactile approaches.
- Limit the number of visual aids and allow sufficient time to read each one.
- When possible, bring videos with captioning for persons who are Deaf or hard of hearing.
- Handout materials should be made available to meeting planners in advance so alternate formats can be produced if requested, or the speakers should bring their own copies in alternate formats.
- Make sure icebreakers or other activities do not exclude people with disabilities. Encourage seated as well as standing activities.

## Removing Barriers: Planning Meetings That Are Accessible to All Participants

- At the beginning of presentations, provide oral descriptions of meeting room layouts, emergency exits, amenities, and Q/A procedures.
- If breaks are included, make sure that you allow adequate time for some people with disabilities to reach the new locations and/or complete tasks.
- Make every effort to keep the meeting room free of extraneous noises.

## Readable Presentation Materials for Everyone

Alternate formats of presentation materials, such as large print, Braille, and electronic formats, are often requested in advance and are discussed in the next section. If you do not know who will be attending the meeting, there are some steps you can take to make materials more readable for everyone.

- Use black ink on white or off-white paper to maximize contrast.
- Avoid glossy paper.
- Use at least 12-point type, but a larger font is often better.
- Avoid italics, except when used as proper titles, or other script type; use a plain font like Helvetica or Verdana.
- Use margins of 1" and ragged right edge.
- Avoid using all caps.
- Make sure there is even spacing between letters.
- Make sure text is not printed over illustrations.

It is good practice to routinely bring several copies of written handouts on a disk or CD. Also, a PowerPoint presentation printed with one slide per page qualifies as a large print handout.

## Alternate Formats

The following accommodations represent some of the more common alternate formats that can make presentations and written materials more accessible to participants with a sensory, cognitive, or hidden disability. Directly ask the person requesting the accommodations to ensure that individual needs are met.



### **Large Print**

Many people who have low vision can read large print. Documents can be converted to large print without the use of outside services. Large print documents are often produced using a non-italic sans serif font such as Helvetica, Arial, or Verdana in 16-point to 18-point type. It is very important to ask the individual specifics about font type and size, because everyone's needs are different. Non-glossy light yellow or off-white paper is best to reduce glare. For more information on producing large print materials, contact Lighthouse International. See Appendix for resources.

### **Braille**

Braille is a system of reading by touch using raised dots that are arranged to represent letters. Not all people who are blind can read Braille. If Braille is requested, most Braille transcription services require receipt of materials in advance; at least two weeks is typical. To locate Braille transcription services in your area, contact a local Center for Independent Living or the state Division of Services for the Blind.

### **Materials on Disk**

Participants who are blind or have low vision may prefer materials on disk so that they can use computers to access the materials via speech output or text magnification. It is a general rule to provide information in text format; however, it is always best to ask.

### **Other Accommodations**

The accommodations mentioned below represent some of the more common or widely used auxiliary aids and services that can provide communication access for people with various disabilities. It is important to note that other accommodations are available and meeting planners can reference the resources in the Appendix for more information.

### **Assistive Listening Devices**

Assistive listening devices are used by people who are hard of hearing and are often plugged directly into the sound system. For this reason it is very important that a high-quality sound system be used. There are numerous types, including an audio loop system, radio frequency systems, and infrared system. Audiovisual companies may be able to provide this equipment. If not, then the local chapter of Self-Help for Hard of Hearing (SHHH) or Center for Independent Living may be able to offer suggestions for where to rent this equipment.

### **Sign Language Interpreters**

Sign language interpreters are certified professionals qualified to interpret effectively and accurately for people who are Deaf or hard of hearing. There are as many as six types of interpretation, the most common being American Sign Language (ASL.) Because of the different types, it is vital that you ask the participant what kind of interpreting they need and prefer.

If the meeting is longer than two hours, then two interpreters are required to avoid fatigue. Make sure to schedule interpreters for all meeting activities including breaks, meals and social activities. As discussed previously in the guide, be sure that proper seating and lighting is provided.

A list of interpreters in your area can be found by contacting a local organization for the Deaf, a Center for Independent Living, or the Registry of Interpreters for the Deaf. See Appendix for resources.

### **Captioning**

If videotapes or films will be shown during the meeting, captioning will be necessary to allow access to individuals who are Deaf or hard of hearing. Captioning is the display of spoken words or sounds as text. Closed captioning allows the display of captions to be turned on or off and is available on most new televisions. Open captioning is visible to all viewers without the use of a decoder. When reserving audio-visual equipment it is important to request a TV or VCR with captioning capacity.

Another form of captioning sometimes used for presentations and meetings is called CART, or Computer-Aided Real-Time Reporting. Using technology developed for the courtroom, a reporter types shorthand that is translated to text on a screen in real time.

### **Scent-Free Environments**

Providing an environment that is free of strong chemicals or fragrances is considered a reasonable accommodation for those who may have environmental sensitivities that can cause a physical reaction. Since not all facilities are smoke-free, recognize that many people with environmental sensitivities, respiratory disabilities, and those who use oxygen cannot tolerate smoke. Designated smoking areas should be far from any meeting room. If a participant requests a fragrance-free meeting in advance, then you should notify other participants and request that they limit their use of scented products. You should also work with facility management to limit scented cleaners in restrooms. Consider including a statement regarding scent-free meetings on registration or other publicity materials.

### **Providing Appropriate Accommodations**

Because of the varying needs of people with disabilities, the best way to accommodate individual needs is to ask participants in advance. You will not need all types of accommodations at each meeting, as many are provided upon request and based on individual needs. During meetings and presentations, staff should watch for those who need assistance. For more detailed information on accommodations that increase accessibility, consult the resource list in the Appendix.

## Other Meeting Activities

A presentation or discussion is often not the only activity that is part of a meeting. When other activities are added to the agenda, consider ways to ensure that they are accessible to everyone. While many of these activities are common at larger meetings and conferences, they can also be a part of small meeting agendas or occur during an informal gathering.

### Food Breaks

Almost every meeting has some kind of food function. Rarely is even a small meeting held without offering coffee or some refreshment. It is important to take into consideration the arrangement of tables, type of food served, and how it is served to ensure accessibility for all participants.

- Tables should be no higher than 34" and two-tiered tables should not be used unless all the items are available on both levels.
- Make sure refreshments or drinks are placed within reach of someone who is seated (usually 48"). It is also helpful to provide straws and lightweight plastic cups.
- When tablecloths reach the floor, be sure to tie or tape down the corners so they don't get caught in the wheels of a wheelchair or scooter.
- If buffets are used, staff or volunteers should be available to offer assistance to those who may need help seeing what is available, reaching the food, or carrying food and drinks.
- Make sure there is an accessible route of travel between tables and aisles. (See Figure 12.)

If food is made available to participants via vending machines or cafeteria-type facilities, these areas should be assessed to make sure they are accessible. In general, vending machines should have adequate space in front and all operating mechanisms should be within reach (15" is the preferred height, and no higher than 48"). Foodservice lines should have food, drinks, trays, utensils, etc. within reach of someone using a wheelchair or other mobility device.

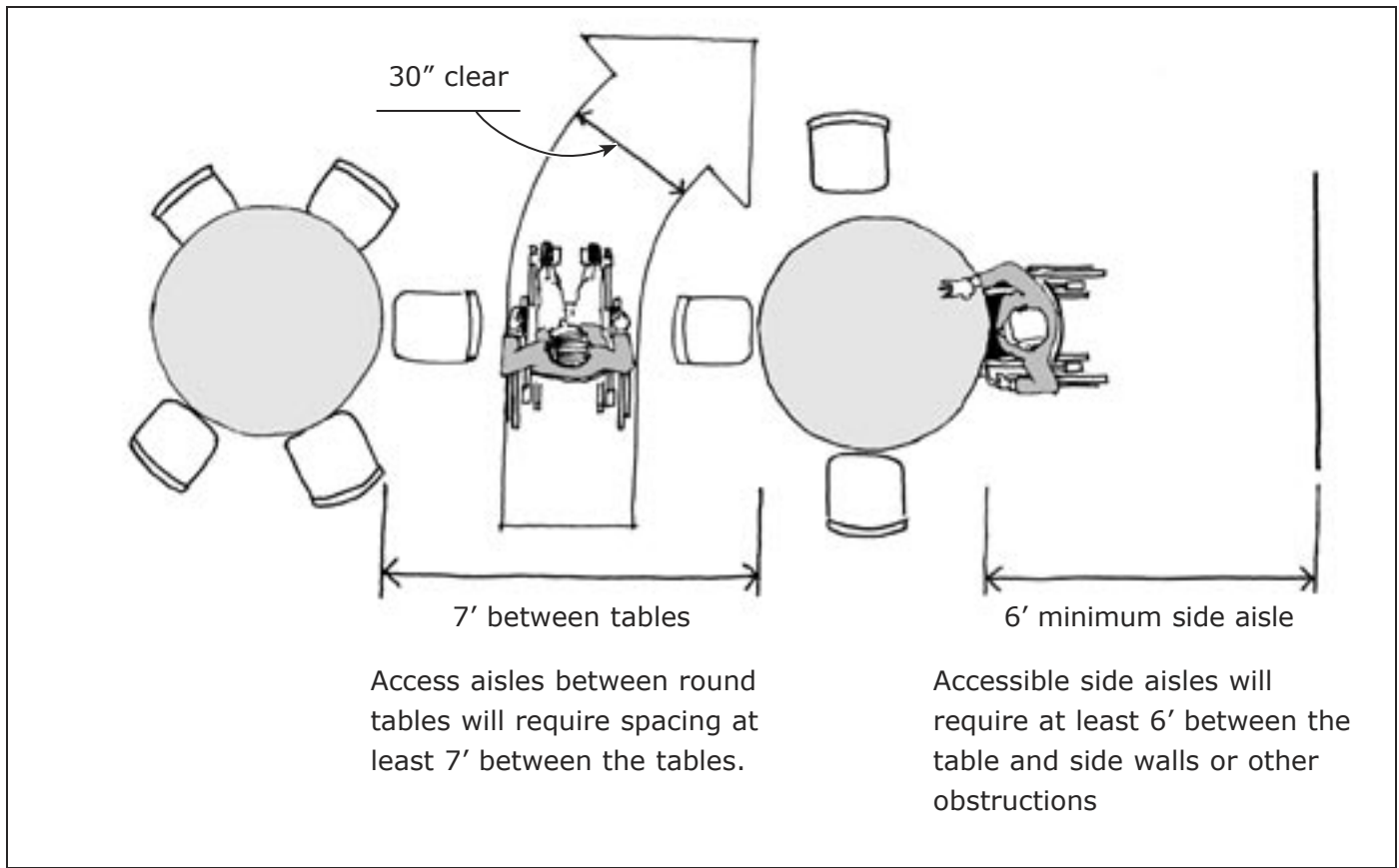

**Figure 12** Aisle Clearance for Round Tables

## Off-site Tours

When a meeting involves an off-site event such as a tour, there are two important considerations. First, confirm through a site visit that the facility to be toured is accessible to people with disabilities and meets ADA design guidelines as much as possible. Second, if you are providing transportation to other participants, you must also arrange for accessible transportation. If participants use a wheelchair or scooter, you may need a van or bus with a lift. Contact your local public transportation provider or disability organization for information on scheduling accessible transportation.

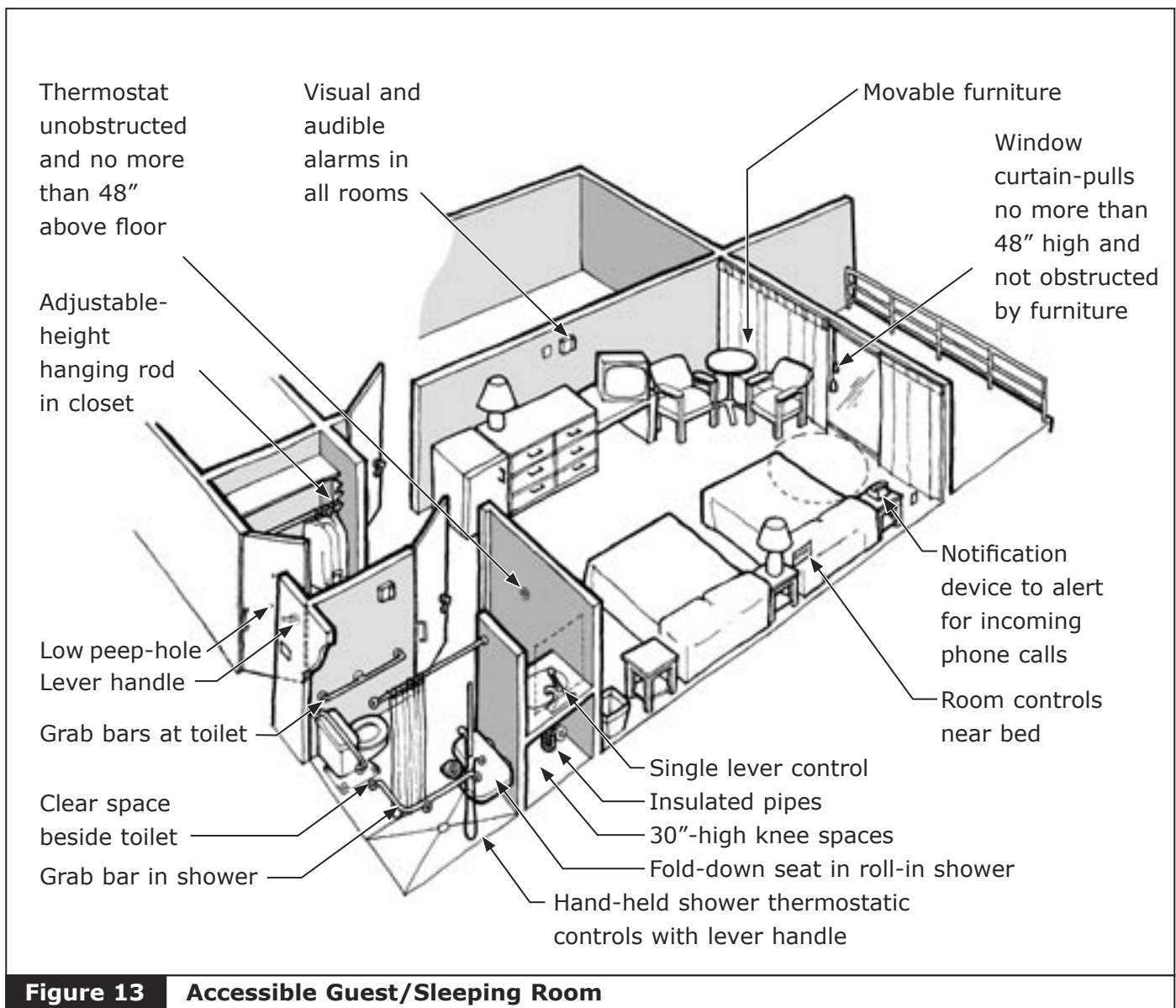

## Overnight Stays

When a meeting requires an overnight stay, carefully examine the accessibility of hotels that are being used for a meeting or recommended to participants. Hotels are required to have a certain number of accessible guest rooms based on the total number of rooms, but the degree of accessibility can vary widely. (See Figure 13.) Do not accept the hotel's word for it when it comes to accessibility of guest rooms; arrange an on-site visit.

While the ADA guidelines provide the specific requirements, there are a few general features that all guest rooms must have to be considered accessible:

- A guest room that is considered wheelchair-accessible must have an accessible route (path at least 36" wide) to all elements of the room, including telephone, bed, living area, balcony, etc.
- Bathrooms must have 36" doorways, 5' turning radius, and grab bars alongside and behind the toilet and in the tub.
- A guest room that is equipped for a guest who is Deaf or hard of hearing should contain visible and audible alarms, a TTY telephone or telephone with volume control, and visual notification systems for phone calls and someone knocking on the door.

Remind the hotel of their legal obligation to guarantee an accessible room. Speak directly with hotel personnel, including managers, to ensure the accessible room is guaranteed and meets the specific needs of individual participants.

### **Tips for an Accessible Last-Minute Meeting**

So what do you do if you have a week or just a day to pull together a meeting and you don't know or have no way of knowing if someone with a disability might attend? Here are some ideas for ways you can make people feel as welcome as possible, even at the last minute.

- Have someone designated to welcome participants and be assigned to handle any requests that may surface.
- Large print materials can often be made by using a larger font on the computer.
- If a wheelchair user comes to a meeting, removing a chair or relocating some furniture can create a useable path or seating area.
- Have a staff member or volunteer available to read an agenda or any handouts to someone who is blind or has low vision or provide orientation to meeting facilities.
- A person can also help take notes for someone who is Deaf or hard of hearing.
- The meeting should always be held in an accessible location. If there are stairs, measures should be taken to provide a ramp, lift, or alternate route. Carrying someone up and down stairs is not an acceptable method for providing access.

## Conclusion

Meetings are such an integral part of our everyday lives that we often overlook ways in which meetings can present barriers to people with disabilities. By taking steps to create a welcoming and accessible environment, you eliminate the need to scramble at the last minute to accommodate all participants. Remember that creating an accessible environment is a work in progress. You are likely to find that these efforts to create a usable environment are enjoyed by many participants and will make for a more rewarding experience for all.



# Accessible Meetings Resources

## Accessible Communication

### **Removing Barriers: Tips and Strategies to Promote Accessible Communication**

This 40-page booklet by the North Carolina Office on Disability and Health provides information on disability awareness, communication aids and alternate formats, inclusive materials, and media relations. It is available on the NCODH website or in printed format.

North Carolina Office on Disability and Health  
FPG Child Development Institute  
University of North Carolina at Chapel Hill  
Campus Box 8185  
Chapel Hill, NC 27599-8185  
[www.fpg.unc.edu/~ncodh](http://www.fpg.unc.edu/~ncodh)

### **Accessibility Guidelines for Speakers**

This 18-page guide by June Isaacson Kailes offers important tips in assuring communication access to a wide audience, including the use of visual aids, sign language interpreters, captioning, assistive listening devices, and alternate formats.

June Isaacson Kailes  
Disability Policy Consultant  
6201 Ocean Front Walk, Suite 2  
Playa del Rey, CA 90293-7556  
(310) 821-7080  
[www.jik.com](http://www.jik.com)

**Lighthouse International**

This organization provides numerous resources related to vision loss, including publications addressing the accessibility of printed materials. (Click on "Publications and Resources," then "Educational Publications," then "Promoting Accessibility and Independent Living.")

Lighthouse International  
11 East 59th Street  
New York, NY 10022-1202  
(800) 829-0500  
(212) 821-9713 (TTY)  
[www.lighthouse.org](http://www.lighthouse.org)

**American Council of the Blind**

This membership organization provides information and referral on all aspects of low vision and blindness. Their website contains resources on Braille and other accessible formats. (Click on "Helpful Resources.")

American Council of the Blind  
1155 15th Street NW, Suite 1004  
Washington, DC 20005  
(800) 424-8666  
[www.acb.org](http://www.acb.org)

**National Braille Association**

This organization provides information and education to those who prepare Braille, and provides Braille materials to persons who are blind or have low vision. The association also provides Braille transcription services.

National Braille Association  
3 Townline Circle  
Rochester, NY 14623-2513  
(585) 427-8260  
[www.nationalbraille.org](http://www.nationalbraille.org)

## **National Center for Hearing Assistive Technology Self Help for Hard of Hearing People**

This center and its supporting organization, Self Help for Hard of Hearing People, provide information on accommodations including captioning and assistive listening devices that may be requested for meetings.

Self Help for Hard of Hearing People  
7910 Woodmont Ave, Suite 1200  
Bethesda, MD 20814  
(301) 657-2248  
(301) 657-2249 (TTY)  
[www.shhh.org](http://www.shhh.org)  
[www.hearingloss.org](http://www.hearingloss.org)

## **Registry of Interpreters for the Deaf (RID)**

RID is a professional organization for interpreters for the Deaf that provides training, certification, and ethical guidelines. Their website contains publications and other information on interpretation.

Registry of Interpreters for the Deaf  
333 Commerce Street  
Alexandria, VA 22314  
(703) 838-0030  
(703) 838-0459 (TTY)  
[www.rid.org](http://www.rid.org)

## **ADA Resources**

### **Regional Disability and Business Technical Assistance Centers (DBTACs)**

This network of regional ADA technical assistance centers is a comprehensive resource for information, materials, technical assistance, and training on the ADA. The website and toll free number provide a means to connect to your regional center, ADA information, and an extensive list of publications.

ADA Technical Assistance Project  
(800) 949-4232  
[www.adata.org](http://www.adata.org)

**The U.S. Architectural and Transportation Barriers Compliance Board  
(Access Board)**

The Access Board develops and disseminates Accessibility Guidelines and Standards, which are minimum guidelines for standards issued under the ADA. The website includes these standards and other publications related to access of facilities, public rights-of-way, transportation, and communication.

The Access Board  
1331 F Street NW, Suite 1000  
Washington, DC 20004-1111  
(800) 872-2253  
(800) 993-2822 (TTY)  
info@access-board.gov  
www.access-board.gov

**United States Department of Justice**

The Disability Rights Section of the Department of Justice (DOJ) provides information and technical assistance on the ADA through the ADA Information Line and the ADA Home Page. Publications can be ordered through the ADA Information Line or downloaded from the website.

Disability Rights Section  
Civil Rights Division  
U.S. Department of Justice  
P.O. Box 66738  
Washington, DC 2005-6738  
(800) 514-0301  
(800) 514-0383 (TTY)  
www.usdoj.gov/crt/ada  
www.ada.gov

**The Center for Universal Design**

The Center is a national research, information and technical assistance center that evaluates, develops, and promotes Universal Design in housing, public and commercial facilities, and related products. It provides publications that address all areas of Universal Design and barrier removal, including ADA Standards Tech Sheets, videos, and Tech Packs on issues related to bathrooms, entrances, and parking. (Click on "Publications.")

The Center for Universal Design  
North Carolina State University, College of Design  
Box 8613  
Raleigh, NC 27695-8613  
(800) 647-6777  
[www.design.ncsu.edu/cud](http://www.design.ncsu.edu/cud)

**The Disability Access Symbols Project**

This project provides accessibility symbols that can be downloaded from the website and used for signage.

Graphic Artists Guild  
90 John Street, Suite 403  
New York, NY 10038-3202  
(800) 500-2672  
[www.gag.org/resources](http://www.gag.org/resources)

## Emergency Procedures

### ADA Design Requirements for Accessible Egress

The Access Board's ADA Accessibility Guidelines include specifications for accessible means of egress, emergency alarms and signage. The website also contains links to other emergency preparedness websites and information.

The Access Board  
1331 F Street NW, Suite 1000  
Washington, DC 20004-1111  
(800) 872-2253  
(800) 993-2822 (TTY)  
info@access-board.gov  
www.access-board.gov

### National Center on Emergency Planning for People with Disabilities (NCEPPD)

The Center offers emergency preparedness kits to assist organizations in developing comprehensive plans that take into account the unique needs of persons with disabilities. It offers remote or on-site training, technical assistance, and other print resources.

Inclusion Research Institute  
1436 Independence Ave. SE  
Washington, DC 20003-1536  
(202) 546-4464  
nceppd@inclusionresearch.org  
www.disabilitypreparedness.com

### U.S. Fire Administration

The Fire Administration is a part of the Federal Emergency Management Agency (FEMA) and provides information on fire related emergencies. Many of the publications are available online.

U.S. Fire Administration  
16825 South Seton Ave.  
Emmitsburg, MD 21727  
www.usfa.fema.gov

## ADA Checklists

### Readily Achievable Checklist: A Survey for Accessibility

Adaptive Environments Center, Inc.  
374 Congress Street, Suite 301  
Boston, MA 02210  
(617) 695-1225  
adaptive@adaptenv.org  
www.adaptenv.org

### Checklist for Buildings and Facilities

Access Board  
1331 F Street NW, Suite 1000  
Washington, DC 20004-1111  
(800) 872-2253  
(800) 993-2822 (TTY)  
info@access-board.gov  
www.access-board.gov/index.htm

## Tools to Assess Accessibility

The information provided here is offered as a service only. The North Carolina Office on Disability and Health does not formally recommend or endorse the equipment listed.

### ADA Accessibility Stick

This multi-function device accurately measures lengths and widths of various building features, such as toilet seat heights and doorway widths, and measures the slope of ramps and curb cuts.

Access, Inc.  
416 Nancy Court  
Lawrence, KS 66049-4601  
(785) 841-0321  
www.adastick.com

**Digital Level**

This computerized device accurately measures ramps, curb cuts, and other sloped surfaces.

STABILA Company  
www.toolking.com/stabila  
(800) 896-7460

**Door Pressure Gauge**

This pen-size device is used to measure the amount of force it takes to open any manual door. It can measure in grams or pounds. A good substitute is a hand-held fish scale.

HMC International Division, Inc.  
5996 South Crocker Street  
Littleton, CO 80120-2054  
(303) 794-2510  
(800) 848-4912, ext. 4452  
www.hmc-international.com

**Rolatape Measure Master MM 12**

This device allows for easy measurement of long distances such as parking spaces or distances between parking and entrances. When it is reset to zero, a person rolls the wheel at the end of the handle along the ground and the distance walked is automatically recorded.

Rolatape® Corporation  
2701 North Van Marter Drive  
Spokane, WA 99206  
(800) 533-9422  
info@rolatape.com  
www.rolatape.com



**RS Means ADA Compliance Pricing Guide: Cost Data for 75 Essential Projects**

This manual, developed by RS Means Company and Adaptive Environments Center, Inc., lists 75 of the most common ADA modifications and includes design suggestions and pricing for various projects.

RS Means Company, Inc.  
63 Smiths Lane  
P.O. Box 800  
Kingston, MA 02364-9988  
(800) 334-3509

**Talking Tape Measure**

This tape measure gives measurement of distances with an electronic "voice."

Arizona Hearing Online Corp.  
6975 W. Western Way, Suite 119  
Tucson, AZ 85713  
(866) 674-3549



# Accessible Meetings Checklist

This checklist is designed to highlight potential barriers to participation in meetings for people with disabilities. Please note that a “Yes” answer does not guarantee that accessibility has been adequately addressed, but this survey will help you to develop plans for improved access. If a potential barrier is detected, please refer to *Removing Barriers: Planning Meetings That Are Accessible to All Participants* or the ADA resources listed at the end of the checklist for more detailed information on barrier removal.

## Meeting Planning

- Does your organization have a policy that requires meetings and events to be held in an accessible location and that appropriate accommodations be provided for participants with disabilities?  
 Yes       No
- Has the meeting facility been assessed to determine accessibility, and have plans been made to remove identified barriers?  
 Yes       No
- Were people with disabilities included in planning the meeting and assessing the meeting facilities?  
 Yes       No

## Notes

---



---



---



---

## Communication

- Can participants request needed accommodations (i.e., alternate formats, sign language interpreters, etc.) through a registration form or other mechanism?  
 Yes       No
- Do staff know how to request sign language interpreters or other accommodations for a participant who is Deaf or hard of hearing?  
 Yes       No
- Do staff know how to make materials available in alternate formats (i.e., large print, Braille) if requested?  
 Yes       No
- Will speakers be informed of ways to make presentations accessible to a wide audience?  
 Yes       No

**Emergency procedures**

- Are there visual emergency signals in restrooms, hallways, and other common areas?  
 Yes       No
- Do strobe fire alarms provide visual and audible signals?  
 Yes       No
- Are evacuation maps of adequate size, height and contrast (recommended to have characters 18 points or larger, 5' high to the center of the sign, and be dark on a light background or vice versa) and are they posted in restrooms, hallways, lobbies, and other common use areas?  
 Yes       No
- Are fire extinguishers stored at a reasonable height (no more than 54" above the floor) for someone in a wheelchair or of small stature?  
 Yes       No
- Is there a plan for evacuation of persons with disabilities from floors above the first floor?  
 Yes       No

**Notes**

---



---



---



---

**Parking**

- Is 1 in every 8 parking spaces designated as van-accessible (8'-wide space with 8'-wide aisle)?\*  
 Yes       No  
 Note: If only 1 space is available, it must be van-accessible
- Is accessible parking labeled with appropriate signage (accessible symbol on above-ground sign)?  
 Yes       No
- Are accessible spaces the closest spaces to the building's accessible entrance (distance is recommended not to exceed 200') and along an accessible route?  
 Yes       No
- Do accessible parking spaces allow people to get in and out on a level, smooth surface?  
 Yes       No
- Is there a curb cut to the sidewalk with a 1:20 slope?  
 Yes       No

\*For every 25 spaces, at least 1 must be accessible. For 501–1000 spaces, 2% should be accessible. For more than 1000 spaces, at least 20 must be accessible, plus 1 for each 100 spaces over 1000.

**Entrance**

- Is at least one of the primary entrances accessible (if there are stairs, there must also be a ramp or lift)?  
 Yes       No
- If the primary entrance is not accessible, is there a clearly marked alternate entrance that can be used independently?  
 Yes       No
- Does the exterior door provide at least a 32"-wide clear opening?  
 Yes       No
- If there is a threshold, is the height a maximum of 1/4", unless beveled?  
 Yes       No
- Is the exterior door heavy and difficult to open (should contain lever-type, U-shaped or push-pull hardware)?  
 Yes       No
- Is there an automatic door?  
 Yes       No

**Notes**

---

---

---

---

---

---

**Exterior route of travel**

- Is the path to the building level and smooth with no stairs, curbs or abrupt changes greater than 1/4"?  
 Yes       No
- Are routes of travel free from sand, gravel, or any debris that results in uneven or unstable surfaces?  
 Yes       No
- Is the path free of obstructions (tree branches, lights, trash cans, signs, etc.)?  
 Yes       No
- Are routes of travel at least 36" wide?  
 Yes       No

**Notes**

---

---

---

---

---

---

---

---

---

---



**Elevators / Stairways**

- Is there an elevator to upper floors?  
 Yes       No
- Do elevator doors remain open a minimum of 5 seconds?  
 Yes       No
- Are elevator doors a minimum of 36" wide when fully opened?  
 Yes       No
- Are emergency buttons grouped at the bottom of the panel 54" or less from the floor?  
 Yes       No
- Do the elevators provide audible tones when moving up or down?  
 Yes       No
- Are graspable handrails provided on both sides of stairways, 34" to 38" high?  
 Yes       No
- Is there adequate lighting in the stairways and contrasting edge marking on stair landings?  
 Yes       No

**Notes**

---



---



---



---

**Signage**

- Are signs mounted at 60" above the floor to the center of the sign?  
 Yes       No
- Do signs use raised, tactile characters (5/8" to 2") with high contrast and non-glare finish?  
 Yes       No
- Is there Braille text in addition to the raised lettering?  
 Yes       No
- Are signs posted directing people to accessible entrances and accessible restrooms?  
 Yes       No
- Are signs outside of rooms mounted on the latch side of the door?  
 Yes       No

**Notes**

---



---



---



---



---



---



---



---

**Telephones / Water fountain**

- Is there at least one water fountain with clear floor space of at least 30" x 48" in front?  
 Yes       No
- Is there one water fountain spout no higher than 36"?  
 Yes       No
- Are water fountain controls mounted on the front or on the side near the front edge, and operable with one closed fist?  
 Yes       No
- Is the pay/public phone's highest operable part no higher than 48"?  
 Yes       No
- If pay/public-use phones are provided, is there clear floor space of at least 30" x 48" in front of at least one?  
 Yes       No
- Does the phone have volume control?  
 Yes       No
- Is a TTY phone available?  
 Yes       No

**Notes**

---



---



---

**Restrooms**

- Is there an accessible toilet stall (5' x 5' clear floor space)?  
 Yes       No
- Does the accessible stall contain grab bars at the side and back at a height of 33" to 36" above the floor?  
 Yes       No
- Is the toilet seat 17" to 19" high?  
 Yes       No
- Is the door on the accessible stall at least 32" wide, swing outward, and equipped with accessible handles (operable with a closed fist)?  
 Yes       No
- Are the soap and towel dispensers or hand dryers at a height reachable from a seated position (48" or less for a forward reach)?  
 Yes       No
- Is a sink accessible (34" maximum height with at least 30" clearance underneath) with insulated exposed pipes?  
 Yes       No
- Can faucets be operated with one closed fist?  
 Yes       No
- Is there a 36" wide path to all fixtures (sink, towels, toilet)?  
 Yes       No



**Meeting rooms**

- Is there a clear pathway throughout the room (at least 36" wide)?  
 Yes       No
- Does the area contain movable chairs and tables that can accommodate a wheelchair, scooter or service animal at various locations throughout the room?  
 Yes       No
- If tables are used, is there 27" of clearance between floor and table apron?  
 Yes       No
- Does the speaker's platform have a ramp with a slope of 1" of rise for every 12" of run?  
 Yes       No
- If there is fixed seating, are there spaces in the front, side or rear of the room with a level floor?  
 Yes       No
- Is lighting adequate for a sign language interpreter, if requested?  
 Yes       No
- Is there a sound system available to accommodate an assistive listening device?  
 Yes       No

- Are lapel or cordless microphones available?  
 Yes       No
- Are efforts made to keep noise levels low?  
 Yes       No

**Notes**

---



---



---



---

**Meeting activities**

- If food or drinks are provided, are tables less than 34" high with all food and drinks within reach?  
 Yes       No
- If an off-site trip is planned, is accessible transportation available?  
 Yes       No
- If an overnight stay is required, has the accessibility of guest rooms been assessed?  
 Yes       No

**Notes**

---



---



---



---

**Guest rooms**

- Is the entry door at least 32" wide with a lever-type handle?  
 Yes       No
- Is there a 36" route of travel to all areas of the room including bed, restroom, telephone, door, and living areas?  
 Yes       No
- Are security locks, temperature controls, light switches, closet rods within reach of a wheelchair user?  
 Yes       No
- Is the doorway into the restroom at least 32" wide?  
 Yes       No
- Is there 5' x 5' area of clear floor space inside the restroom?  
 Yes       No

- Does the restroom contain grab bars in the tub/shower and around the toilet?  
 Yes       No
- Is there 29" or less of knee clearance under the sink with lever-type faucets?  
 Yes       No
- Does the guest room equipped for someone who is Deaf or hard of hearing contain visible alarm and a TTY or telephone with volume control?  
 Yes       No

**Notes**

---

---

---

---

---

---

---

---

---

---

This material was adapted from *Checklist for Readily Achievable Barrier Removal*, Adaptive Environments Center, Inc. and Barrier Free Environments, Inc., Boston, MA.

2004. Developed by the North Carolina Office on Disability and Health, a collaborative partnership between the NC Division of Public Health and UNC-CH FPG Child Development Institute.

For more information, contact:

NC Office on Disability and Health, FPG Child Development Institute, UNC-CH, Campus Box 8185, Chapel Hill, NC 27599-8185

Phone/TTY: (919) 843-3531; Fax (919) 966-0862

Email: odhpubs@mail.fpg.unc.edu

website: www.fpg.unc.edu/~ncodh



## **North Carolina Office on Disability and Health**

is a partnership of the NC Division of Public Health of the Department of Health and Human Services and the FPG Child Development Institute at UNC-CH to promote the health and wellness of persons with disabilities in North Carolina.

## **The Center for Universal Design**

is part of the College of Design at North Carolina State University in Raleigh, North Carolina. The Center serves as a national research, information, and technical assistance center that evaluates, develops, and promotes accessible and universal design in housing, public and private facilities, and consumer products.

## **Other publications on related topics**

### ***Removing Barriers to Health Care: A Guide for Health Professionals***

**Center for Universal Design and the North Carolina Office on Disability and Health. 1998. 17 pages.**

This book walks the health care provider through the process of making a medical facility physically accessible. It is complete with specific ADA requirements, picture illustrations, and some helpful tips on creating accessible environments and services.

### ***Removing Barriers: Tips and Strategies to Promote Accessible Communication***

**North Carolina Office on Disability and Health and Woodward Communications. 1999. 40 pages.**

This booklet is an easy-to-read, quick reference guide that addresses the basics on ways to effectively communicate and interact with people with disabilities.

### ***Removing Barriers to Health Clubs and Fitness Centers: A Guide for Accommodating All Members, Including People with Disabilities and Older Adults***

**North Carolina Office on Disability and Health, 2001. 40 pages.**

This guide provides ways you can make a health club's facility and services more accessible to all people, including people with disabilities and older adults. Illustrations demonstrate how barriers in the physical environment can be removed and how exercise equipment can be designed to create a welcoming facility.

Copies of these books can be downloaded in PDF or html format from the NCODH website at

**<http://www.fpg.unc.edu/~ncodh/>**

Alternate formats are available on request.



**UNC**

FPG  
CHILD DEVELOPMENT  
INSTITUTE